



DATA SHEET

Article number : 09980284

load-shedding relays

RLR

for avoiding current peaks



Function

Load-shedding relays switch off a connected consumer when another consumer connected via the coil input is switched on. Therefore, simultaneous operation of powerful consumers such as night storage heaters and continuous-flow heaters can be avoided, preventing surges. Devices from the RLR series have one potential-free NC relay with a housing width of just one module width unit. In comparison to the RLR 1, the RLR 2 has an additional drop-off delay for the operation of electronic continuous-flow heaters.

Features

coil input up to 5.3 A, potential-free relay as NC contact up to 1 A, drop delay 0 (RLR 1) or 2 mains half-waves (RLR 2), module width just 1 unit (17.5 mm), protection class IP20

Mounting

quick fastening to mounting rail, any installation position

Applications

The load-shedding relays can be used anywhere where the simultaneous operation of powerful electrical consumers is undesired and a consumer operating over a long time can be switched off, e.g. for night storage heaters and continuous-flow heaters.

Technical data

Technical Data	RLR 2
Series	RLR 2
max. Surveillance current	43 A
Number of (n.o, n.c., change-over)	0 1 0
Tripping delay	20 ms
Switch-on threshold range shading current	3.1 A ... 5.3 A
Operating voltage (AC)	230 V
	control input
Rated voltage (AC)	230 V
Rated current In	6.7 A ... 39 A
Rated power	0.5 VA ... 4 VA
Specification	relays
Rated voltage (AC)	400 V
Rated current (AC)	1 A
Rated power	max. 250 VA
Switching frequency	max. 30 1/min
Allowed utilization category	AC-3
	screw-type terminal bottom (coil input)
Cross section solid	1-wire: 2.5 mm ² ... 16 mm ²
Cross section stranded	1-wire: 2.5 mm ² ... 16 mm ²
	screw-type terminal top (load circuit)
Cross section solid	1-wire: 0.75 mm ² ... 4 mm ²
Cross section stranded	1-wire: 0.75 mm ² ... 4 mm ²
	General data
Duty cycle	continuous operation (Duty cycle ≤ 100 %)
Operating position	optional
Mechanical endurance	min. 100 · 10 ⁶ switching cycles
Electrical endurance	min. 1 · 10 ⁶ switching cycles
Ambient temperature	-20 °C ... 40 °C
Housing type	distribution board housing
Installation type	Mounting rail (35 mm)
Housing material	polycarbonate (PC)
Protection class	IP40

Technical Data	RLR 2
Width	17.5 mm
Height	87 mm
Depth	65 mm
Installation depth	60 mm
Module widths	1
Weight	0.088 kg
Design requirements/Standards	EN 60715

Dimensions

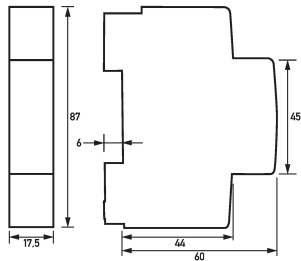

Dimensioned drawing load-shedding relays RLR

Wiring example

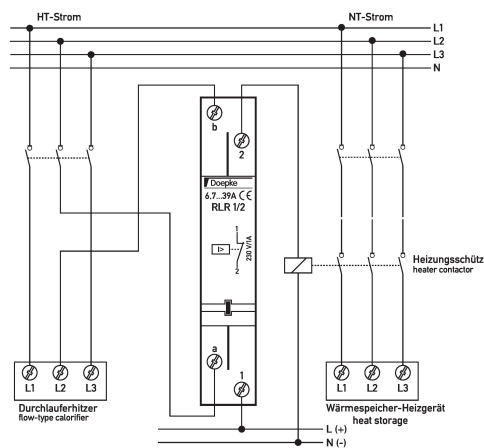

Wiring example load-shedding relays RLR