



DATA SHEET
Article number: 09177911



residual current circuit-breaker
DFS 4 125-4/0,50-A R
sensitive to pulsating and alternating currents Type A



Function

Residual current circuit-breakers (RCCBs) are components for implementing protective measure "Automatic disconnection of the power supply" as per IEC 60364-4-41 or corresponding national installation regulations. Series DFS 4 devices are compact two or four-pole residual current circuit-breakers. In the standard design, they only take up four module width units of space. Although DFS 4 devices for AC and pulsating DC residual currents are actually designed for three-phase networks, they can also be used in single-phase networks. However, in addition to these, special variants are also available for single or three-phase operation in the form of the AC/DC sensitive designs (type B, type B+). In spite of the compact dimensions, a number of different tripping currents and characteristics are available at rated currents, depending on the design, up to 125 A. They also have large two-tier terminals for large conductor cross-sections, a practical multi-functional switch toggle and can be provided with labels using free-of-charge software. Type A residual current circuit-breakers are sensitive to pulsating and alternating currents. This function is independent of the mains voltage. Devices in the standard design are intended for monitoring circuits with a rated voltage of 230 V, 400 V and a rated frequency of 50 Hz.

Features

tripping not dependent on mains and auxiliary voltage, sensitive to AC residual currents and pulsating DC residual currents (type A), compact design for all rated currents, high short-circuit resistance, double-sided two-tier terminals for large conductor cross-section and busbar, switch position indicator, viewing window for labels, multifunction switch toggle with three positions: "on", "off" and "tripped", Neutral conductor position right

Mounting

quick fastening to mounting rail, any installation position, supply from any direction

Applications

Power supplies to residential and purpose-built buildings as well as industrial facilities with TN-S, TT and TN-C-S networks. In IT networks, the residual current circuit-breakers of this series can be set to switch off in the event of a second fault. Excluded is the application in TN-C systems and for the protection of installations in which electronic equipment could generate smooth DC currents or residual currents with frequencies other than 50 Hz. Comprehensive protection is not provided in this case. For these applications we recommend our AC/DC sensitive residual current circuit-breakers (Type B or B+).

Accessories

automatic reclosing devices DFA, terminal caps KA, information stickers HAS, auxiliary switches DHi, restart locks DFS WES, software DBS

Technical Data

Series	DFS 4 A
Number of poles	4
Residual current type	A
Rated current (AC)	125 A
Rated residual current $I_{\Delta n}$	0.5 A
Short-time delayed	false
Selective	false
min. Operating voltage range of test circuit	200 V
max. Operating voltage range of test circuit	250 V
Maximum disconnection times	$1 \cdot I_{\Delta n} : \leq 300 \text{ ms}; 5 \cdot I_{\Delta n} : \leq 40 \text{ ms}$
	load circuit
Specification	load disconnect contact
min. Contact opening	4 mm
Rated voltage (AC)	230 V, 400 V
Rated current (AC)	125 A
Rated short-circuit current	10 kA
Surge current strength	0.25 kA

max. Total rated switching capacity	1250 A
Rated insulation voltage	400 V
Rated impulse withstand voltage	4 kV
Rated frequency	50 Hz
Current heat loss per current path	11.2 W
Thermal Backup-fuse OCPD	80 A
Short-circuit backup-fuse SCPD	125 A
Back-up fuse type	gG
I ² t strength	60 kA ² s
Dynamic current strength I _p	6.4 kA
	Screw-type terminal top and bottom (load circuit)
Neutral conductor position	right
Protection against direct contact	DGUV V3, VDE 0660-514, finger and back-of-hand proof
Connection C1 max. number of conductors per terminal	2 (conductors of same type and cross-section)
Cross section solid	1-wire: 1.5 mm ² ... 50 mm ² ; 2-wire: 1.5 mm ² ... 16 mm ²
Connecting capacity flexible	1-wire: 1.5 mm ² ... 50 mm ² ; 2-wire: 1.5 mm ² ... 16 mm ²
Cross section stranded	1-wire: 1.5 mm ² ... 50 mm ² ; 2-wire: 1.5 mm ² ... 16 mm ²
Cross section AWG, solid	15 ... 1
Cross section AWG, stranded	15 ... 1
Cross section AWG, flexible	15 ... 1
Cross section AWG, flexible with ferrule	15 ... 1
Tightening torque	2.5 Nm ... 3 Nm
	General data
Operating position	optional
max. operating altitude above MSL	2000 m
mechanical endurance	min. 5000 cycles
electrical endurance	min. 2000 cycles
Surrounding atmosphere	normal environmental conditions
Storage temperature	-35 °C ... 75 °C
Ambient temperature	-25 °C ... 40 °C
Climate resistance	according to IEC 60068-2-30: humid heat / cyclic (25 °C / 55 °C; 93 % / 97 % RH)
Shock resistance	20 g / 20 ms duration
Fatigue limit	> 5 g (f ≤ 80 Hz, duration > 30 min.)
Housing type	distribution board housing
Installation type	Mounting rail (35 mm)
Housing material	thermoplastic
Protection class	IP20 (installed: IP40)
sealable	true
Width	72 mm
Height	85 mm
Depth	75 mm
Installation depth	69 mm
Module widths	4
Weight	0.416 kg
Design requirements/Standards	VDE 0664-10, DIN EN 61008-1
Degree of pollution	2
Certifications	VDE

Dimensions

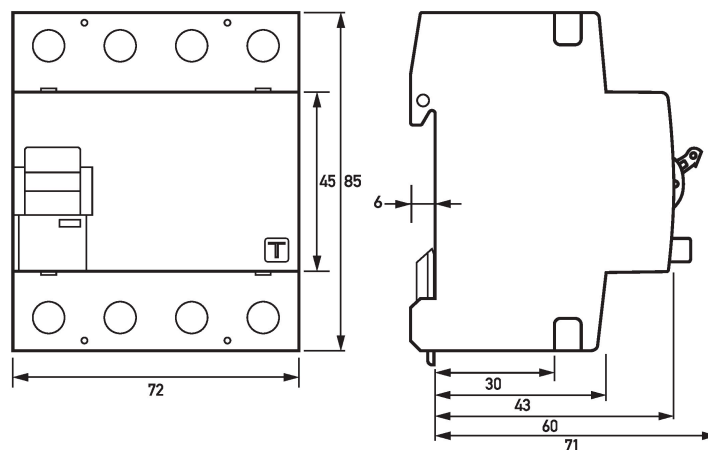

Dimensional drawing DFS 4 A, 4-pole N right (Group view)

Wiring example

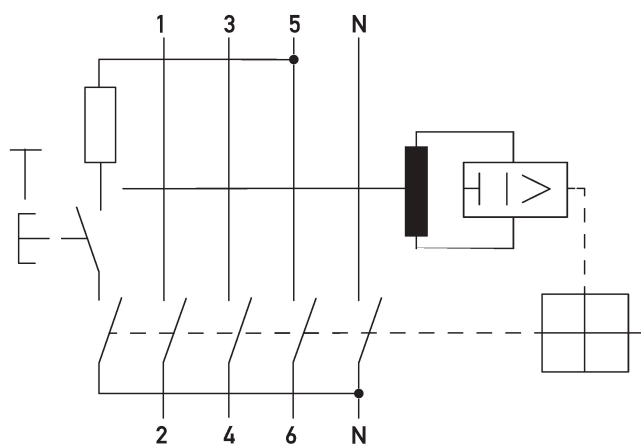

Wiring diagram DFS 4 A, 4-pole N right