



## DATA SHEET

Article number: 09156984

### residual current circuit-breaker DFS 4 080-4/0,30-B SK V500

AC/DC sensitive type B, Rated voltage 290 V, 500 V

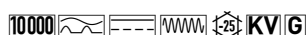

#### Function

Residual current circuit-breakers (RCCBs) are components for implementing protective measure "Automatic disconnection of the power supply" as per IEC 60364-4-41 or corresponding national installation regulations. Series DFS 4 devices are compact two or four-pole residual current circuit-breakers. In the standard design, they only take up four module width units of space. Although DFS 4 devices for AC and pulsating DC residual currents are actually designed for three-phase networks, they can also be used in single-phase networks. However, in addition to these, special variants are also available for single or three-phase operation in the form of the AC/DC sensitive designs (type B, type B+). In spite of the compact dimensions, a number of different tripping currents and characteristics are available at rated currents, depending on the design, up to 125 A. They also have large two-tier terminals for large conductor cross-sections, a practical multi-functional switch toggle and can be provided with labels using free-of-charge software. Type B residual current circuit-breakers detect smooth DC residual currents and all other residual currents at frequencies up to 150,000 Hz. The operating voltage required for this is taken from the mains supply. Correct power supply is ensured when the voltage between the mains conductors is  $\geq 50$  V. Pulsating and AC residual currents are detected independent of the mains voltage. For residual current circuit-breakers with characteristic curve SK, the frequency response of the tripping current is designed so that residual currents with high frequencies, such as in the clock frequency range for frequency converters, as opposed to the rated frequency are detected with significantly reduced sensitivity. Undesired trips caused by leakage currents can therefore be widely avoided. However, fire protection depending on the rated residual current of the switch (0.03 A, 0.1 A or 0.3 A) is only provided for residual currents with frequencies up to 1 kHz, 300 Hz or 100 Hz, while the devices with tripping current frequency response B+ or NK offer protection over the entire tripping frequency range up to 20 kHz or 150 kHz, respectively. Devices in design V are made for special voltages. Devices in the standard design are intended for circuits with a rated frequency of 50 Hz.

#### Features

High level of immunity against leakage and residual currents due to operational conditions from frequency 1 kHz and higher, AC/DC sensitive for residual currents with frequencies and mixed frequencies of 0 Hz (smooth direct current) up to 150 kHz, high availability even of voltage-independent detection of smooth DC residual current and AC residual current with frequencies not equal to 50/60 Hz thanks to full functional compatibility with mains voltages from at least 50 V AC on any two active conductors, mains-voltage-independent tripping when type A residual currents occur, compact design for all rated currents, high short-circuit resistance, double-sided two-tier terminals for large conductor cross-section and busbar, switch position indicator, viewing window for labels, multifunction switch toggle with three positions: "on", "off" and "tripped", Neutral conductor position left

#### Mounting

quick fastening to mounting rail, any installation position, supply preferably from above

#### Applications

Main distribution boards in power supplies to large areas with TN-S, TT and TN-C-S systems, with sub-distribution boards in which power electronics equipment may be used or connected, such as frequency converters, switching power supplies, high-frequency converters, UPS installations and photovoltaic systems. Selective residual current circuit-breakers in most cases protect the cables from the main distribution board to the sub-distribution boards.

#### Notes

suitable for use in 50 Hz AC networks, RCCBs for other frequencies available upon request, Not designed for use in direct current networks or on the output side of controlled electrical equipment such as frequency converters.

#### Accessories

automatic reclosing devices DFA, terminal caps KA, information stickers HAS, auxiliary switches DHi, restart locks DFS WES, software DBS

#### Technical Data

Series	DFS 4 B SK V
Number of poles	4
Residual current type	B

Tripping characteristic curve	SK
Rated current (AC)	80 A
Rated residual current $I_{\Delta n}$	0.3 A
Short-time delayed	true
Selective	false
min. Operating voltage range of test circuit	200 V
max. Operating voltage range of test circuit	550 V
Minimum rated operating voltage (Type A/AC operation)	0 V AC
Minimum rated operating voltage (Type B operation)	50 V AC
Non-trip time	10 ms
Tripping frequency	0 Hz ... 150 kHz
Maximum disconnection times	$1 \cdot I_{\Delta n}: \leq 300 \text{ ms}; 5 \cdot I_{\Delta n}: \leq 40 \text{ ms}$
Internal consumption	max. 2.2 W
	<b>load circuit</b>
Specification	load disconnect contact
min. Contact opening	4 mm
Rated voltage (AC)	290 V, 500 V
Rated current (AC)	80 A
Rated short-circuit current	10 kA
Surge current strength	3 kA
max. Total rated switching capacity	800 A
Rated insulation voltage	500 V
Rated impulse withstand voltage	4 kV
Rated frequency	50 Hz
Current heat loss per current path	5 W
Thermal Backup-fuse OCPD	80 A
Short-circuit backup-fuse SCPD	125 A
Back-up fuse type	gG
$I^2t$ strength	48 kA <sup>2</sup> s
Dynamic current strength $I_p$	6 kA
	<b>Screw-type terminal top and bottom (load circuit)</b>
Neutral conductor position	left
Protection against direct contact	DGUV V3, VDE 0660-514, finger and back-of-hand proof
Connection C1 max. number of conductors per terminal	2 (conductors of same type and cross-section)
Cross section solid	1-wire: 1.5 mm <sup>2</sup> ... 50 mm <sup>2</sup> ; 2-wire: 1.5 mm <sup>2</sup> ... 16 mm <sup>2</sup>
Connecting capacity flexible	1-wire: 1.5 mm <sup>2</sup> ... 50 mm <sup>2</sup> ; 2-wire: 1.5 mm <sup>2</sup> ... 16 mm <sup>2</sup>
Cross section stranded	1-wire: 1.5 mm <sup>2</sup> ... 50 mm <sup>2</sup> ; 2-wire: 1.5 mm <sup>2</sup> ... 16 mm <sup>2</sup>
Cross section AWG, solid	15 ... 1
Cross section AWG, stranded	15 ... 1
Cross section AWG, flexible	15 ... 1
Cross section AWG, flexible with ferrule	15 ... 1
Tightening torque	2.5 Nm ... 3 Nm
	<b>General data</b>
Operating position	optional
max. operating altitude above MSL	2000 m
mechanical endurance	min. 5000 cycles
electrical endurance	min. 2000 cycles
Surrounding atmosphere	normal environmental conditions
Storage temperature	-40 °C ... 70 °C
Ambient temperature	-25 °C ... 40 °C
Climate resistance	according to IEC 60068-2-30: humid heat / cyclic (25 °C / 55 °C; 93 % / 97 % RH)
Shock resistance	20 g / 20 ms duration
Fatigue limit	> 5 g (f ≤ 80 Hz, duration > 30 min.)
Housing type	distribution board housing
Installation type	Mounting rail (35 mm)
Housing material	thermoplastic
Protection class	IP20 (installed: IP40)
sealable	true
Width	72 mm
Height	85 mm
Depth	75 mm
Installation depth	69 mm
Module widths	4
Weight	0.492 kg
Design requirements/Standards	VDE 0664-10, VDE 0664-40, ÖVE/ÖNORM E 8601, DIN EN 61008-1, EN 62423
Degree of pollution	2

Dimensions

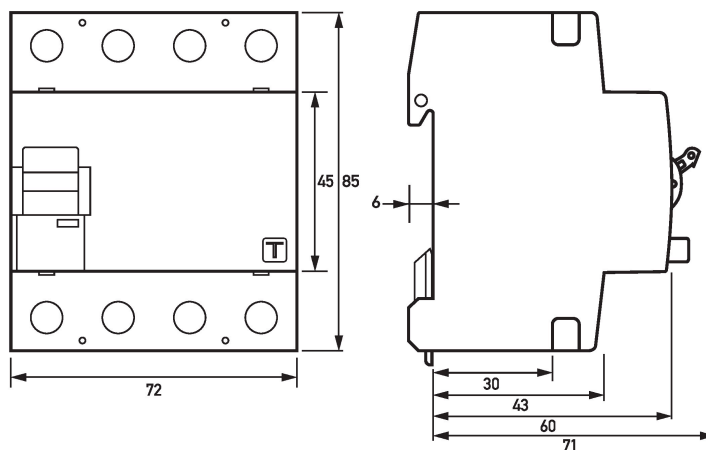

Dimensional drawing DFS 4 B SK V500, 4-pole (Group view)

Wiring example

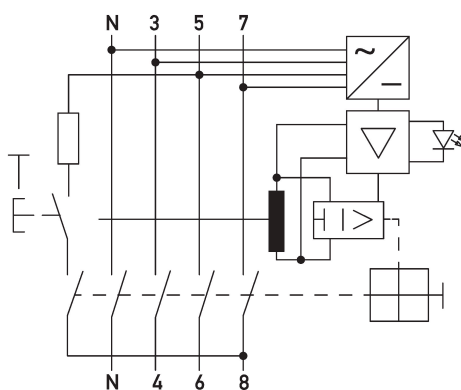

Wiring diagram DFS 4 B SK V500, 4-pole

Diagrams

