



## DATA SHEET

Article number: 09136821HD

### residual current circuit-breaker

### DFS 4 040-4/0,30-F R HD

sensitive to residual currents Type F, for harsh environments



#### Function

Residual current circuit-breakers (RCCBs) are components for implementing protective measure "Automatic disconnection of the power supply" as per IEC 60364-4-41 or corresponding national installation regulations. Series DFS 4 devices are compact two or four-pole residual current circuit-breakers. In the standard design, they only take up four module width units of space. Although DFS 4 devices for AC and pulsating DC residual currents are actually designed for three-phase networks, they can also be used in single-phase networks. However, in addition to these, special variants are also available for single or three-phase operation in the form of the AC/DC sensitive designs (type B, type B+). In spite of the compact dimensions, a number of different tripping currents and characteristics are available at rated currents, depending on the design, up to 125 A. They also have large two-tier terminals for large conductor cross-sections, a practical multi-functional switch toggle and can be provided with labels using free-of-charge software. Switches for residual current type F are mains voltage-independent and record type A sinusoidal alternating and pulsating DC residual currents as well as residual currents with mixed frequencies that differ from 50 Hz. For example, these can arise when using single-phase frequency converters. Devices in the standard design are intended for monitoring circuits with a rated voltage of 230 V, 400 V and a rated frequency of 50 Hz. With an airtight, encapsulated tripping mechanism from a special alloy and the stainless steel latch, residual current circuit-breakers in HD design are protected, in particular from corrosion, corrosive gases, moisture and extreme temperature fluctuations.

#### Features

sensitive to AC residual currents and pulsating DC residual currents at the mains frequency (type A) as well as AC residual currents with multiple frequency components not equal to 50 Hz, high immunity against surge currents and mains-voltage-operated secondary current impulses, compact design for all rated currents, high short-circuit resistance, double-sided two-tier terminals for large conductor cross-section and busbar, switch position indicator, viewing window for labels, multifunction switch toggle with three positions: "on", "off" and "tripped", Neutral conductor position right

#### Mounting

quick fastening to mounting rail, any installation position, supply from any direction

#### Applications

Modern domestic installations with LED lighting systems and single-phase frequency converters, Ideal for systems where RCCBs Type A have a tendency towards faulty trips due to surge residual currents, Commercial and industrial installations with TN-S, TT- and TN-C-S systems, where power electronics equipment is used without galvanic isolation from the mains, e.g. switching power supplies, high-frequency converters, photovoltaic installations and UPS equipment with frequency converters without transformers, Not permitted for use in TN-C networks; not permitted for protecting systems in which electronic equipment could generate smooth DC currents. Comprehensive protection is not provided in this case. For these applications we recommend our AC/DC sensitive residual current circuit-breakers (Type B or B+).

#### Notes

suitable for use in 50 Hz AC networks, Not designed for use in direct current networks or on the output side of controlled electrical equipment such as frequency converters.

#### Accessories

automatic reclosing devices DFA, terminal caps KA, information stickers HAS, auxiliary switches DHi, restart locks DFS WES, software DBS

#### Technical Data

|                                       |            |
|---------------------------------------|------------|
| Series                                | DFS 4 F HD |
| Number of poles                       | 4          |
| Residual current type                 | F          |
| Rated current (AC)                    | 40 A       |
| Rated residual current $I_{\Delta n}$ | 0.3 A      |
| Short-time delayed                    | true       |
| Selective                             | false      |

|   |   |
|---|---|
| min. Operating voltage range of test circuit            | 200 V   |
| max. Operating voltage range of test circuit            | 250 V   |
| Non-trip time   | 10 ms   |
| Maximum disconnection times                             | $1 \cdot I\Delta n: \leq 300 \text{ ms}; 5 \cdot I\Delta n: \leq 40 \text{ ms}$                         |
|   | <b>load circuit</b>   |
| Specification   | load disconnect contact   |
| min. Contact opening                                    | 4 mm  |
| Rated voltage (AC)                                      | 230 V, 400 V  |
| Rated current (AC)                                      | 40 A  |
| Rated short-circuit current                             | 10 kA   |
| Surge current strength                                  | 3 kA  |
| max. Total rated switching capacity                     | 500 A   |
| Rated insulation voltage                                | 400 V   |
| Rated impulse withstand voltage                         | 4 kV  |
| Rated frequency   | 50 Hz   |
| Current heat loss per current path                      | 1.3 W   |
| Thermal Backup-fuse OCPD                                | 40 A  |
| Short-circuit backup-fuse SCPD                          | 100 A   |
| Back-up fuse type                                       | gG  |
| $I^2t$ strength   | 48 kA <sup>2</sup> s  |
| Dynamic current strength $I_p$                          | 6 kA  |
|   | <b>Screw-type terminal top and bottom (load circuit)</b>  |
| Neutral conductor position                              | right   |
| Protection against direct contact                       | DGUV V3, VDE 0660-514, finger and back-of-hand proof  |
| Connection C1 Maximum number of conductors per terminal | 2 (conductors of same type and cross-section)   |
| Cross section solid                                     | 1-wire: 1.5 mm <sup>2</sup> ... 50 mm <sup>2</sup> ; 2-wire: 1.5 mm <sup>2</sup> ... 16 mm <sup>2</sup> |
| Connecting capacity flexible                            | 1-wire: 1.5 mm <sup>2</sup> ... 50 mm <sup>2</sup> ; 2-wire: 1.5 mm <sup>2</sup> ... 16 mm <sup>2</sup> |
| Cross section stranded                                  | 1-wire: 1.5 mm <sup>2</sup> ... 50 mm <sup>2</sup> ; 2-wire: 1.5 mm <sup>2</sup> ... 16 mm <sup>2</sup> |
| Cross section AWG, solid                                | 15 ... 1  |
| Cross section AWG, stranded                             | 15 ... 1  |
| Cross section AWG, flexible                             | 15 ... 1  |
| Cross section AWG, flexible with ferrule                | 15 ... 1  |
| Tightening torque                                       | 2.5 Nm ... 3 Nm   |
|   | <b>General data</b>   |
| Operating position                                      | optional  |
| max. operating altitude above MSL                       | 2000 m  |
| mechanical endurance                                    | min. 5000 cycles  |
| electrical endurance                                    | min. 2000 cycles  |
| Surrounding atmosphere                                  | harsh environmental conditions  |
| Storage temperature                                     | -40 °C ... 70 °C  |
| Ambient temperature                                     | -25 °C ... 60 °C  |
| Climate resistance                                      | according to IEC 60068-2-30: humid heat / cyclic (25 °C / 55 °C; 93 % / 97 % RH)                        |
| Shock resistance  | 20 g / 20 ms duration   |
| Fatigue limit   | > 5 g (f ≤ 80 Hz, duration > 30 min.)   |
| Housing type  | distribution board housing  |
| Installation type                                       | Mounting rail (35 mm)   |
| Housing material  | thermoplastic   |
| Protection class  | IP20 (installed: IP40)  |
| sealable  | true  |
| Width   | 72 mm   |
| Height  | 85 mm   |
| Depth   | 75 mm   |
| Installation depth                                      | 69 mm   |
| Module widths   | 4   |
| Weight  | 0.429 kg  |
| Design requirements/Standards                           | VDE 0664-10, DIN EN 61008-1, ÖVE/ÖNORM E 8601   |
| Degree of pollution                                     | 2   |

Dimensions

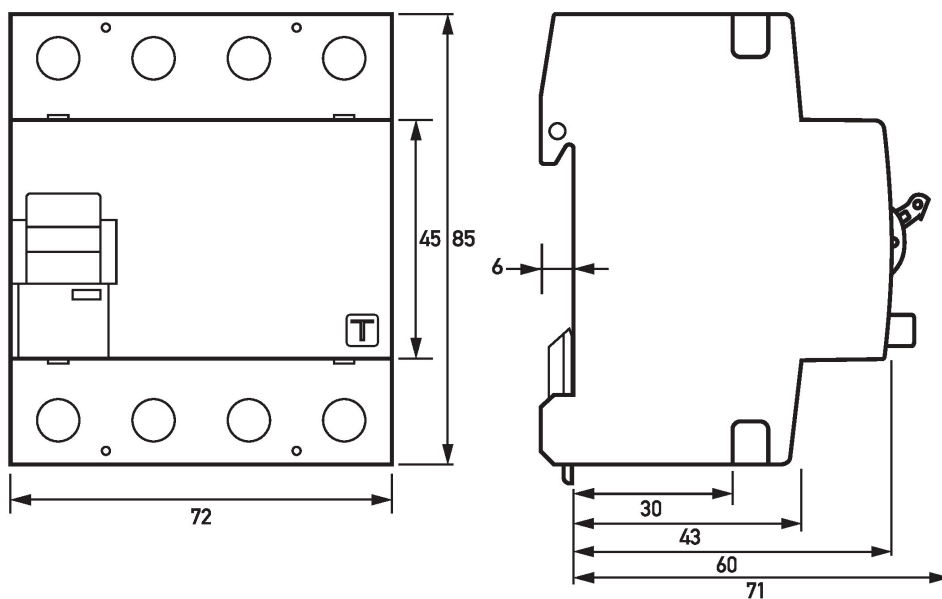

Dimensional drawing DFS 4 F HD, 4-pole N right (Group view)

Wiring example

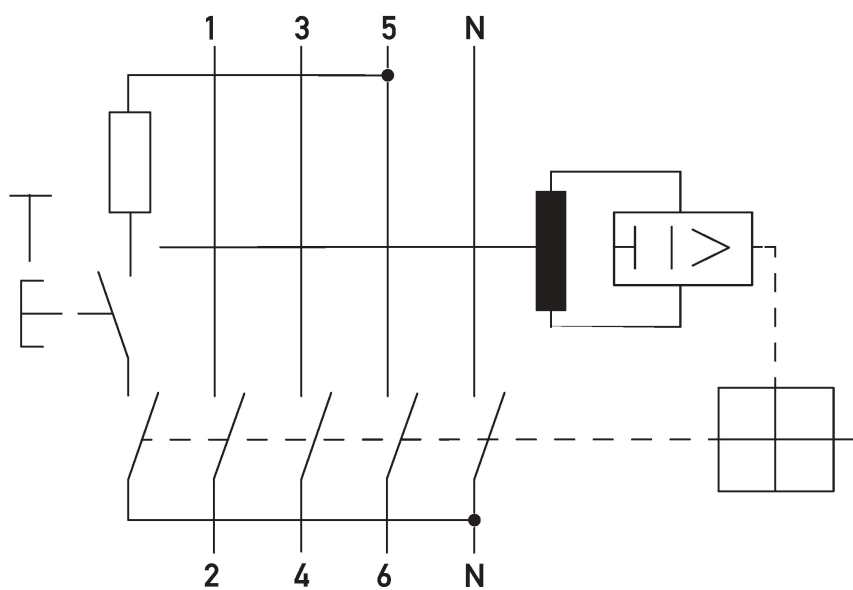

Wiring diagram DFS 4 F HD, 4-pole N right