



DATA SHEET

Article number: 09134850HD

residual current circuit-breaker DFS 4 040-4/0,03-A EV NA HD

sensitive to pulsating and alternating currents Type A, for electromobility with DC detection, emergency switching-off function, for harsh environments



Function

Residual current circuit-breakers (RCCBs) are components for implementing protective measure "Automatic disconnection of the power supply" as per IEC 60364-4-41 or corresponding national installation regulations. Series DFS 4 devices are compact two or four-pole residual current circuit-breakers. In the standard design, they only take up four module width units of space. Although DFS 4 devices for AC and pulsating DC residual currents are actually designed for three-phase networks, they can also be used in single-phase networks. However, in addition to these, special variants are also available for single or three-phase operation in the form of the AC/DC sensitive designs (type B, type B+). In spite of the compact dimensions, a number of different tripping currents and characteristics are available at rated currents, depending on the design, up to 125 A. They also have large two-tier terminals for large conductor cross-sections, a practical multi-functional switch toggle and can be provided with labels using free-of-charge software. Type A residual current circuit-breakers are sensitive to pulsating and alternating currents. This function is independent of the mains voltage. RCCB of series EV are also fitted with an active mains-voltage-dependent function for detecting smooth DC residual currents and a tripping threshold of 6 mA. This prevents possible pre-magnetisation of an upstream type A or F residual current circuit-breaker due to a smooth DC residual current, so that this circuit-breaker can continue fulfilling its protective function. They are only designed for use in charging columns or wall boxes for charging electric vehicles as per DIN VDE 0100-722. RCCBs in design EV must not be used in place of a type B or B+ residual current circuit-breaker. DFS with emergency shut-off function ('NA' variant) make it possible to connect control elements, e.g. push-buttons for disconnecting the RCCB in emergency situations. The device is connected via the compact, factory mounted module; parallel wiring of multiple DHS is also possible. The integrated LED signals tripping by a control element as well as a possible wire breakage. In this state, reclosing of the RCCB is prevented. With an airtight, encapsulated tripping mechanism from a special alloy and the stainless steel latch, residual current circuit-breakers in HD design are protected, in particular from corrosion, corrosive gases, moisture and extreme temperature fluctuations.

Features

tripping not dependent on mains and auxiliary voltage, sensitive to AC residual currents and pulsating DC residual currents (type A), supplementary function, dependent on the mains voltage, for detecting smooth DC residual currents and emergency switching off function, tripping threshold of 6 mA for smooth DC residual currents, LED display for when the supplementary function is active, No additional wiring overhead, compact design for all rated currents, high short-circuit resistance, double-sided two-tier terminals for large conductor cross-section and busbar, switch position indicator, viewing window for labels, multifunction switch toggle with three positions: "on", "off" and "tripped", Neutral conductor position left

Mounting

quick fastening to mounting rail, any installation position, supply from any direction

Applications

These RCCBs are only designed for use in charging stations for electric vehicles, Not permitted for protecting systems in which electronic equipment may cause residual currents with frequencies not equal to 50 Hz. AC/DC sensitive residual current circuit-breakers of type B or B+ must be used in this case.

Accessories

terminal caps KA, information stickers HAS, restart locks DFS WES, software DBS

Technical Data

Series	DFS 4 A EV NA HD
Number of poles	4
Residual current type	A
Rated current (AC)	40 A
Rated residual current $I_{\Delta n}$	0.03 A
DC tripping threshold	6 mA
Short-time delayed	false
Selective	false
min. Operating voltage range of test circuit	250 V
max. Operating voltage range of test circuit	440 V

Internal consumption	max. 1.7 W
	Auxiliary device (6-mA-DC detection)
Additional device AE1 operating voltage	85 V ... 440 V (AC)
	Auxiliary device (Emergency shut-off device)
Additional device AE2 operating voltage	50 V ... 440 V (AC)
Auxiliary device AE2 Voltage of the monitoring circuit	12 V (DC)
Auxiliary device AE2 Current consumption of the monitoring circuit	max. 1 mA (DC)
max. Auxiliary device AE2 Cable length of the monitoring circuit	500 m
	load circuit
Specification	load disconnect contact
min. Contact opening	4 mm
Rated voltage (AC)	230 V, 400 V
Rated current (AC)	40 A
Rated short-circuit current	10 kA
Surge current strength	3 kA
max. Total rated switching capacity	500 A
Rated insulation voltage	400 V
Rated impulse withstand voltage	4 kV
Rated frequency	50 Hz
Current heat loss per current path	1.2 W
Thermal Backup-fuse OCPD	40 A
Short-circuit backup-fuse SCPD	100 A
Back-up fuse type	gG
I ^t strength	48 kA ² s
Dynamic current strength I _p	6 kA
	Auxiliary switch (additional emergency shut-off device)
Specification	switching contact
Number of poles (total)	1
Contact assignment	1 CO
Rated voltage (AC)	12 V ... 230 V
Rated voltage (DC)	12 V ... 110 V
Tolerance of rated voltage	max. 5 %
	Screw-type terminal top and bottom (load circuit)
Neutral conductor position	left
Protection against direct contact	DGUV V3, VDE 0660-514, finger and back-of-hand proof
Connection C1 Maximum number of conductors per terminal	2 (conductors of same type and cross-section)
Cross section solid	1-wire: 1.5 mm ² ... 50 mm ² ; 2-wire: 1.5 mm ² ... 16 mm ²
Connecting capacity flexible	1-wire: 1.5 mm ² ... 50 mm ² ; 2-wire: 1.5 mm ² ... 16 mm ²
Cross section stranded	1-wire: 1.5 mm ² ... 50 mm ² ; 2-wire: 1.5 mm ² ... 16 mm ²
Cross section AWG, solid	15 ... 1
Cross section AWG, stranded	15 ... 1
Cross section AWG, flexible	15 ... 1
Cross section AWG, flexible with ferrule	15 ... 1
Tightening torque	2.5 Nm ... 3 Nm
	Screw-type terminal top and bottom (Emergency shut-off device, auxiliary switches)
max. Cable length	500 m
Allowed types of wires	solid conductor, flexible conductor, stranded conductors with ferrule
Connection C2 Maximum number of conductors per terminal	2 (conductors of same type and cross-section)
Cross section solid	1-wire: 1 mm ² ... 1.5 mm ² ; 2-wire: 1 mm ² ... 1.5 mm ²
Cross section flexible with ferrule	1 mm ² ... 1.5 mm ²
Cross section stranded	1-wire: 1 mm ² ... 1.5 mm ² ; 2-wire: 1 mm ² ... 1.5 mm ²
Cross section AWG, solid	17 ... 16
Cross section AWG, stranded	17 ... 16
Cross section AWG, flexible with ferrule	17 ... 16
Tightening torque	max. 0.8 Nm
Thickness busbar	min. 0.8 mm
	General data
Operating position	optional
max. operating altitude above MSL	2000 m
mechanical endurance	min. 5000 cycles
electrical endurance	min. 2000 cycles
Surrounding atmosphere	harsh environmental conditions
Storage temperature	-40 °C ... 70 °C
Ambient temperature	-25 °C ... 60 °C
Climate resistance	according to IEC 60068-2-30: humid heat / cyclic (25 °C / 55 °C; 93 % / 97 % RH)
Shock resistance	20 g / 20 ms duration

Fatigue limit	> 5 g ($f \leq 80$ Hz, duration > 30 min.)
Housing type	distribution board housing
Installation type	Mounting rail (35 mm)
Housing material	thermoplastic
Protection class	IP20 (installed: IP40)
sealable	true
Width	81 mm
Height	85 mm
Depth	75 mm
Installation depth	69 mm
Module widths	4.5
Weight	0.538 kg
Design requirements/Standards	VDE 0664-10, DIN EN 61008-1, VDE V 0664-120
Degree of pollution	2

Dimensions

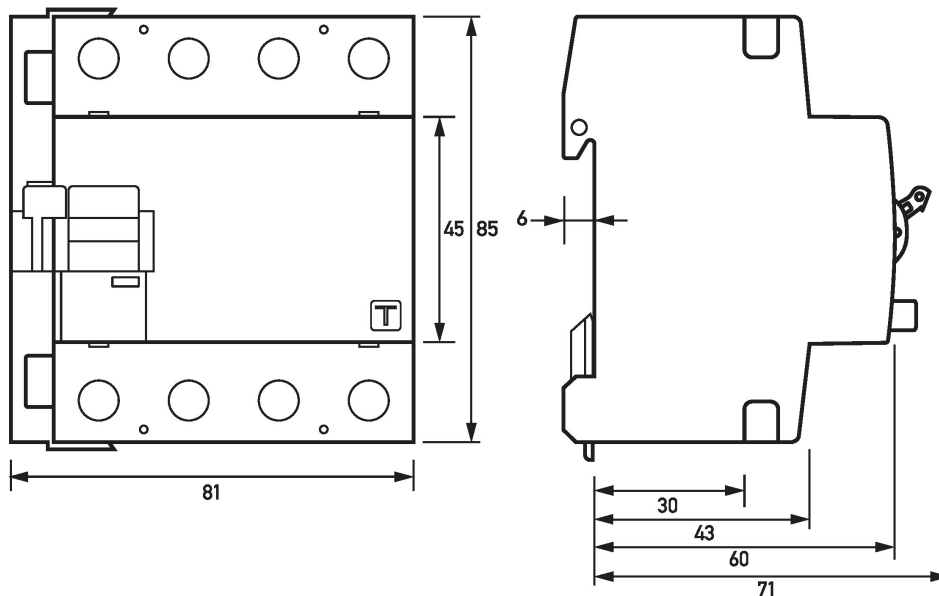

Dimensional drawing DFS 4 A EV NA HD, 4-pole (Group view)

Wiring example

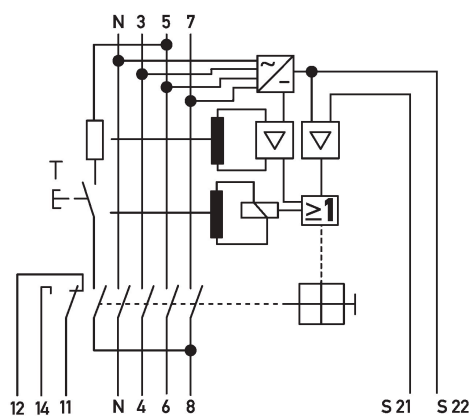

Wiring diagram DFS 4 A EV NA HD, 4-pole