



DATA SHEET

Article number: 09114889

residual current circuit-breaker DFS 4 016-4/0,03-B+ MI

AC/DC sensitive type B+, fire protection according to VDE 0100-420, for mobile installations



10000 kHz KV G

Function

Residual current circuit-breakers (RCCBs) are components for implementing protective measure "Automatic disconnection of the power supply" as per IEC 60364-4-41 or corresponding national installation regulations. Series DFS 4 devices are compact two or four-pole residual current circuit-breakers. In the standard design, they only take up four module width units of space. Although DFS 4 devices for AC and pulsating DC residual currents are actually designed for three-phase networks, they can also be used in single-phase networks. However, in addition to these, special variants are also available for single or three-phase operation in the form of the AC/DC sensitive designs (type B, type B+). In spite of the compact dimensions, a number of different tripping currents and characteristics are available at rated currents, depending on the design, up to 125 A. They also have large two-tier terminals for large conductor cross-sections, a practical multi-functional switch toggle and can be provided with labels using free-of-charge software. Switches with residual current characteristic B+ detect smooth DC residual currents as well as all other type B+ residual currents as per DIN VDE 0664-400. The operating voltage required for this is taken from the mains supply. Correct power supply is ensured when the voltage between the mains conductors is ≥ 50 V. Type A residual currents are detected regardless of the mains voltage. They also seamlessly detect residual currents in all frequencies up to 20 kHz with a maximum tripping threshold of 420 mA. Devices with characteristic B+ therefore provide better fire protection, i.e. they provide fire protection even when residual currents with frequencies above the rated frequency occur. Protection as per VDE 0100 part 410 is provided with a corresponding earth resistance via the entire frequency range of residual current detection. The maximum permissible earth resistance is calculated as the quotient from the permissible touch voltage and the maximum trip residual current in the entire detected frequency range. The MI variant is also equipped with a tripping threshold of 6 mA for DC residual currents additional to the AC/DC sensitivity of Type B or B+. This prevents pre-magnetisation of upstream RCCBs Type A or F, so that they can continue to fulfil their protective function. Devices in the standard design are intended for monitoring circuits with a rated voltage of 230 V, 400 V and a rated frequency of 50 Hz.

Features

tripping threshold of 6 mA for smooth DC residual currents, AC/DC sensitive for residual currents with frequencies and mixed frequencies of 0 Hz (smooth direct current) up to 20 kHz, Fire protection as per VDE 0100-420, mains-voltage-independent tripping when type A residual currents occur, voltage-dependent detection of smooth DC and AC residual currents with frequencies not equal to 50 Hz, full functionality with mains voltages from at least 50 V AC on any two active conductors, compact design for all rated currents, high short-circuit resistance, double-sided two-tier terminals for large conductor cross-section and busbar, switch position indicator, viewing window for labels, multifunction switch toggle with three positions: "on", "off" and "tripped", Neutral conductor position left

Mounting

quick fastening to mounting rail, any installation position, supply preferably from above

Applications

Ideally suited for mobile use in power distributors e.g. for rental equipment, where upstream RCCBs of an unknown type are present. Due to the low DC tripping threshold, the AC-DC sensitive RCCB version MI also can be operated downstream of an RCCB Type A or F, commercial and industrial and also mobile installations with TT, TN-S and TN-C-S systems, where power electronics equipment is used without galvanic isolation from the mains, e.g. frequency converters, switching power supplies, high-frequency converters, photovoltaic installations and UPS equipment with frequency converters without transformers, Facilities at risk of fire

Accessories

automatic reclosing devices DFA, terminal caps KA, information stickers HAS, auxiliary switches DHi, restart locks DFS WES, software DBS

Technical Data

Series	DFS 4 B+MI
Number of poles	4
Residual current type	B+
Rated current (AC)	16 A
Rated residual current $I_{\Delta n}$	0.03 A
DC tripping threshold	6 mA

Short-time delayed	true
Selective	false
min. Operating voltage range of test circuit	250 V
max. Operating voltage range of test circuit	440 V
Minimum rated operating voltage (Type A/AC operation)	0 V AC
Minimum rated operating voltage (Type B operation)	50 V AC
Non-trip time	10 ms
Tripping frequency	0 Hz ... 20 kHz
Maximum disconnection times	1 · IΔn: ≤ 300 ms; 5 · IΔn: ≤ 40 ms
Internal consumption	max. 2.2 W
	load circuit
Specification	load disconnect contact
min. Contact opening	4 mm
Rated voltage (AC)	230 V, 400 V
Rated current (AC)	16 A
Rated short-circuit current	10 kA
Surge current strength	3 kA
max. Total rated switching capacity	500 A
Rated insulation voltage	400 V
Rated impulse withstand voltage	4 kV
Rated frequency	50 Hz, 60 Hz
Current heat loss per current path	0.2 W
Thermal Backup-fuse OCPD	16 A
Short-circuit backup-fuse SCPD	100 A
Back-up fuse type	gG
I ² t strength	48 kA ² s
Dynamic current strength I _p	6 kA
	Screw-type terminal top and bottom (load circuit)
Neutral conductor position	left
Protection against direct contact	DGUV V3, VDE 0660-514, finger and back-of-hand proof
max. Connection C1 Number of conductors per terminal	2 (conductors of same type and cross-section)
Cross section solid	1-wire: 1.5 mm ² ... 50 mm ² ; 2-wire: 1.5 mm ² ... 16 mm ²
Connecting capacity flexible	1-wire: 1.5 mm ² ... 50 mm ² ; 2-wire: 1.5 mm ² ... 16 mm ²
Cross section stranded	1-wire: 1.5 mm ² ... 50 mm ² ; 2-wire: 1.5 mm ² ... 16 mm ²
Cross section AWG, solid	15 ... 1
Cross section AWG, stranded	15 ... 1
Cross section AWG, flexible	15 ... 1
Cross section AWG, flexible with ferrule	15 ... 1
Tightening torque	2.5 Nm ... 3 Nm
	General data
Operating position	optional
max. operating altitude above MSL	2000 m
mechanical endurance	min. 5000 cycles
electrical endurance	min. 2000 cycles
Surrounding atmosphere	normal environmental conditions
Storage temperature	-35 °C ... 75 °C
Ambient temperature	-25 °C ... 40 °C
Climate resistance	according to IEC 60068-2-30: humid heat / cyclic (25 °C / 55 °C; 93 % / 97 % RH)
Shock resistance	20 g / 20 ms duration
Fatigue limit	> 5 g (f ≤ 80 Hz, duration > 30 min.)
Housing type	distribution board housing
Installation type	Mounting rail (35 mm)
Housing material	thermoplastic
Protection class	IP20 (installed: IP40)
sealable	true
Width	72 mm
Height	85 mm
Depth	75 mm
Installation depth	69 mm
Module widths	4
Weight	0.487 kg
Design requirements/Standards	VDE 0664-10, VDE 0664-400, ÖVE/ÖNORM E 8601, DIN EN 61008-1
Degree of pollution	2

Dimensions

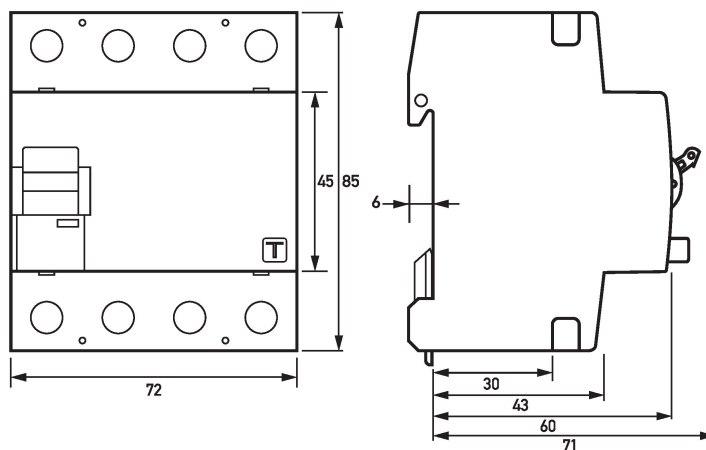

Dimensional drawing DFS 4 B+ MI, 4-pole (Group view)

Wiring example

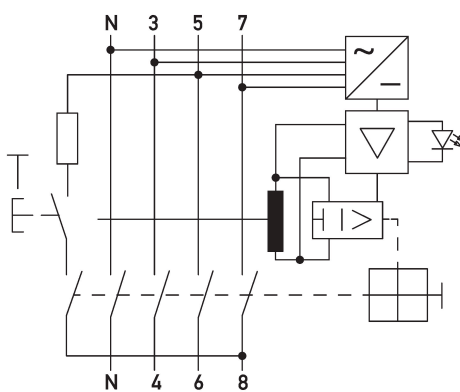

Wiring diagram DFS 4 B+ MI, 4-pole

Diagrams

