

Liability

All information contained in this document belonging to Doepke Schaltgeräte GmbH is protected by copyright. The reproduction and processing, altering and/or transfer against payment of this information is permissible only with express written approval from Doepke Schaltgeräte GmbH. This information is provided solely as customer information and does not constitute a binding guarantee or undertaking. It is subject to technical or commercial changes at any time. Binding information can only be provided in response to specific enquiries.

The use of this document is solely at your own discretion. Doepke Schaltgeräte GmbH accepts no liability for any loss or damage arising from the use of this document, in particular breakdown of operations, loss of profit, loss of information and data, or consequential damage caused by a defect, except in cases of compulsory liability, e.g. as provided for by the German Product Liability Law, or in cases of premeditation, gross negligence or that are due to a breach of fundamental contractual obligations.

Compensation for breach of fundamental contractual obligations shall, however, be limited to foreseeable damage typical of the contract, provided there is no premeditation or gross negligence.

Copyright © Doepke Schaltgeräte GmbH



Technical information

February 2026



Contents

1. Why “AC-DC sensitive”?

1.1.	AC-DC sensitive residual current monitors and frequency converters	page 7
1.2.	Residual currents or leakage currents?	
1.2.1.	Residual currents	
1.2.2.	Leakage currents	page 8
1.3.	Installations with frequency converters	page 9
1.3.1.	Insulation fault at the frequency converter input	
1.3.2.	Insulation fault at the intermediate circuit capacitor	page 10
1.3.3.	Fault between frequency converter and motor	
1.3.4.	Single-phase operated frequency converter	page 12
1.4.	General observation on leakage currents	
1.4.1.	Stationary leakage currents	page 13
1.4.2.	Use of single-phase operated frequency converters	page 14
1.4.3.	Variable leakage currents	
1.4.4.	Transient leakage currents	page 15
1.5.	Countermeasures	page 16
1.5.1.	Reduction of stationary leakage currents	
1.5.2.	Reduction of variable leakage currents	page 17
1.5.3.	Additional possibilities for reducing stationary and variable leakage currents	
1.5.4.	Reduction of transient leakage currents when switching an electrical installation with electronic equipment on and off	page 18
1.5.5.	Avoiding natural oscillation (resonance) by an EMC filter	page 19
1.5.6.	Inductive leakage currents	page 20
1.5.7.	Changes to existing electrical installations	
1.6.	Integrated EMC filters	page 21

2. Why use an “RCM”?

2.1.	What is a residual current monitor (RCM)?	page 23
2.2.	What components make up an RCM?	
2.3.	RCM with switch-off device	page 24
2.4.	Different types of RCM	page 25
2.4.1.	RCM Type A	page 26
2.4.2.	RCM Type F	
2.4.3.	RCM Type B	
2.4.4.	RCM Type B+	page 27
2.5.	Identification of the different RCM types	
2.6.	Protection target and degree of protection of an RCM	page 28

3. Evaluation of residual currents

- 3.1. RMS evaluation of residual currents ————— page 30
- 3.2. Frequency-selective evaluation of residual currents ————— page 33

4. RCM applications and application areas

- 4.1. RCM applications and application areas (examples) ————— page 37
- 4.2. Fire protection and protection of property (facilities at risk of fire)
- 4.3. Fire protection and protection of property (facilities at risk of fire in agriculture)
- 4.4. Repeated insulation testing of cables and lines ————— page 38
- 4.5. IT infrastructures
- 4.6. Preventive maintenance ————— page 39
- 4.7. Unmanned photovoltaic and wind power plants, and pumping and lifting stations ————— page 40
- 4.8. Summary ————— page 41

5. References to the use of RCMs in standards

- 5.1. References to RCMs in standards ————— page 43
 - 5.1.1. DIN VDE 0100-600:06/2017
 - 5.1.2. Guidelines for testing electrical installations ————— page 44
 - 5.1.3. DGUV regulation 3:01/05
 - 5.1.4. Damage prevention guidelines ————— page 46
 - 5.1.5. DIN VDE 0100-530-06:2018

6. References to the use of RCMs in standards

- 6.1. DRCM Type A ————— page 49
 - 6.1.1. Intelligent DCTR transformers ————— page 50
 - 6.1.2. The DCTR Type A and DCTR Type B series
 - 6.1.3. e.Guard RCM B series ————— page 51

7. Residual current monitoring with Doepke e.Guard

- 7.1. Intelligent residual current monitoring with e.Guard ————— page 55
 - 7.1.1. The five levels within the e.Guard system

8. How to select residual current monitors (RCMs)

- 8.1. Basic circuits for electronic equipment ————— page 66
- 8.2. How to select RCM systems ————— page 68

9. Appendix

- 9.1. List of abbreviations ————— page 70
- 9.2. Item numbers ————— page 71





Part I

Why “AC-DC sensitive”?

1. Why "AC-DC sensitive"?

1.1. AC-DC sensitive residual current monitors and frequency converters

Multi-phase operated electronic equipment such as frequency converters (FC) or inverters may produce a smooth DC residual current in the event of a fault, as shown in Fig. 1.

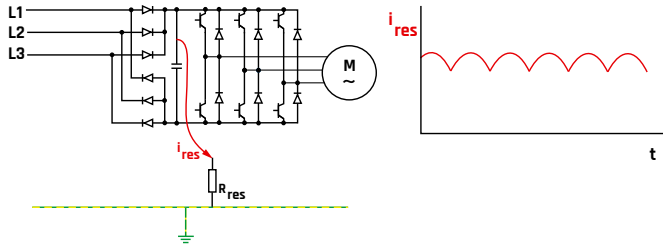

Fig. 1: Production of an almost smooth DC residual current (simplified representation of a frequency converter with B6 bridge rectifier, intermediate circuit capacitor, output stage and motor)

This smooth DC residual current that is generated by the B6 connection at the frequency converter input would not be detected by conventional Type AC, Type A or Type F RCMs (residual current monitors). This is because the magnetisation in the summation current transformer does not vary over time and without this there can be no inductive transfer of energy to the evaluation unit. Depending on how high it is, the DC residual current instead results in pre-magnetisation of the transformer core, thus reducing the sensitivity to any additional AC residual currents or even preventing their detection by the RCM altogether.

Formation of the DC residual current from the three individual currents of the line conductors L1, L2 and L3 is shown in greater detail in Fig. 5 (p. 10).

1.2. Residual currents or leakage currents?

1.2.1. Residual currents

Residual currents are predominantly resistive and are created by insulation faults between voltage-carrying parts and earth, for example as a result of dirt and moisture in a device.

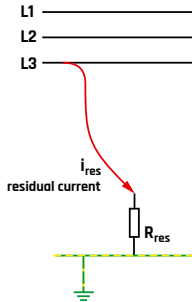

Fig. 2: AC residual current

1.2.2. Leakage currents

Leakage currents are usually capacitive currents which occur under operating conditions and which flow to earth, for example through capacitors in EMC filters (EMC: electromagnetic compatibility) that are being used as anti-interference measures or due to the capacitance of long shielded cables (see Fig. 3).

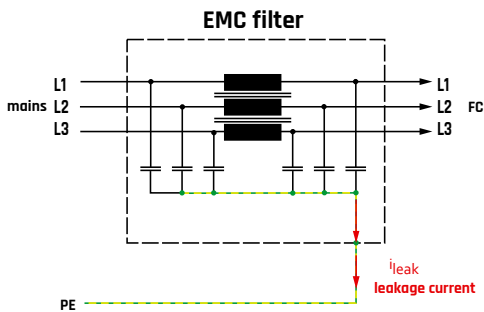

Fig. 3: Capacitive leakage current (simplified representation of an EMC filter)

Both residual currents and leakage currents can simultaneously include multiple frequency components which differ significantly from the mains frequency of 50 Hz, depending on the application and the electrical installation. RCMs cannot distinguish between residual currents and leakage currents, which are therefore evaluated identically. For example, if the sum of all the leakage currents flowing exceeds the tripping threshold for the residual current monitor, the RCM may signal a residual current even though there is no fault of this kind in the electrical installation.

1.3. — Installations with frequency converters

1.3.1. — Insulation fault at the frequency converter input

An earth fault is present at the frequency converter input. A purely sinusoidal residual current of 50 Hz is flowing. If this residual current is high enough, the RCM will signal it reliably.

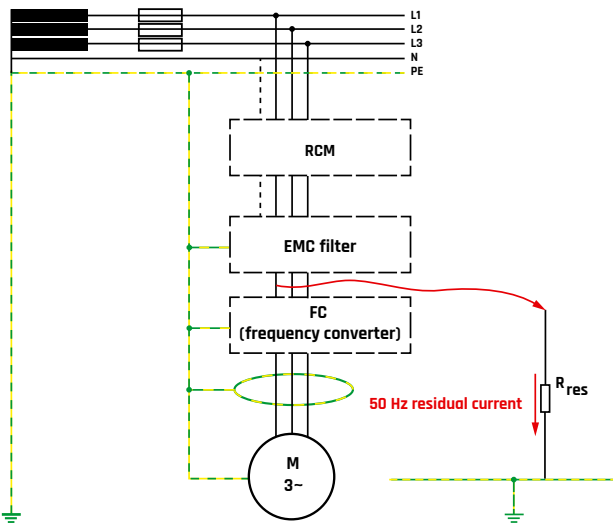

Fig. 4: Residual current at 50 Hz

1.3.2. — Insulation fault at the intermediate circuit capacitor

An insulation fault occurs between the positive terminal of the intermediate circuit capacitor and the frequency converter housing. This fault may be caused, for example, by dirt or exposure to moisture. An almost smooth DC residual current is flowing. If Type B RCMs are used, reliable signalling by the monitor is guaranteed if the DC residual current is high enough.

Note — In many frequency converters, the two poles of the intermediate circuit (DC+, DC-) are routed to the exterior in the form of two terminals, e.g. for energy recovery. They are therefore particularly vulnerable to dirt and/or moisture.

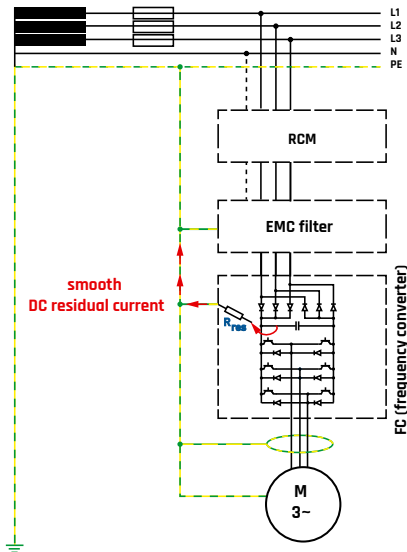

Fig. 5: DC residual current

1.3.3. — Fault between frequency converter and motor

The motor is operated at an output frequency (also referred to as the machine or motor frequency) of 10 Hz. The switching frequency (also referred to as the chopper or elementary frequency) of the frequency converter is 8 kHz. A residual current comprising an extremely large number of frequency components is now flowing. In addition to the

output frequency of 10 Hz with a lower amplitude, the switching frequency of the frequency converter at 8 kHz and its harmonic components of 16 kHz, 24 kHz, 32 kHz etc. are also present as significant components. A 50 Hz component with low amplitude, generated by the input-side six-pulse bridge rectifier of the frequency converter, is also present. Correct signalling by the monitor is generally also guaranteed in this case when Type B RCMs are used. In exceptional cases (depending on the EMC filter measures used), the higher-frequency components in the residual current may flow back predominantly via the filter capacitances rather than exclusively via the star point, meaning that they are not fully detected by the residual current monitor. If necessary, a fault should be simulated using a suitable test device in order to determine whether correct signalling is guaranteed.

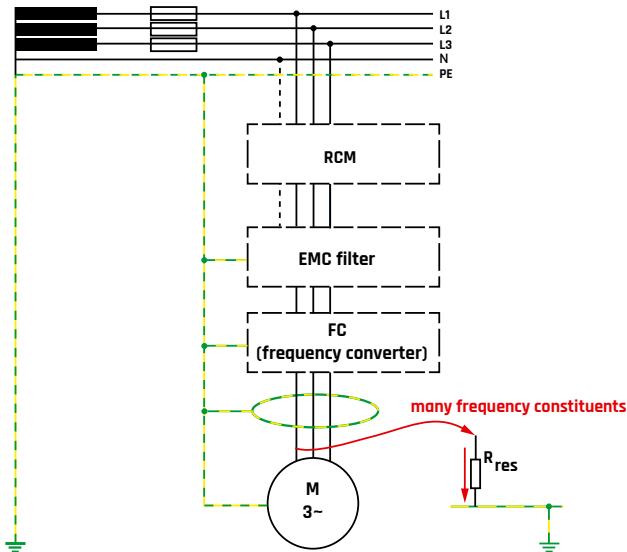

Fig. 6: Residual current with frequency mix

Note — Alternatively, a Type B+ residual current monitor can also be used for the faults cited as examples in Section 1.3.



1.3.4. **Single-phase operated frequency converter**

If single-phase operated frequency converters are used in an electrical installation, a Type F residual current monitor is generally sufficient. In the event of a fault, either a sinusoidal AC residual current or a pulsating DC residual current resulting from the rated frequency (50 Hz) occurs depending on the fault point. The residual current usually contains additional spectral components of the output frequency and of the switching frequency along with harmonic components. Smooth DC residual currents cannot generally occur. However, specially designed single-phase operated frequency converters contain a PFC stage or a boost converter in the intermediate circuit in order to raise the intermediate circuit voltage so that electric motors designed for a rated voltage of 400 V can also be connected. However, if frequency converters of this type are used, residual currents with a high direct component may occur in the event of a fault and go undetected by Type A or F RCMs. Only Type B or B+ RCMs may be used in this case. The manufacturer of the frequency converter is obliged to provide information on this topic in the relevant documentation. For further information, see the table of basic wiring diagrams in Section 4.1 "Basic circuits for electronic equipment", which also shows the possible residual currents which may result.

1.4. **General observation on leakage currents**

A distinction is made between stationary, variable and transient leakage currents. Once again, this will be illustrated by an installation that has an asynchronous motor operated with a frequency converter. To ensure compliance with the relevant EMC regulations, the frequency converter may only be operated using an upstream EMC filter, although this may also be integrated into the frequency converter itself. Since the pulse-width modulated output voltage of the frequency converter has a very steep edge and therefore contains harmonic components of high amplitudes and frequencies, the motor (again, in order to comply with EMC regulations) may only be connected to the frequency converter using a shielded cable.

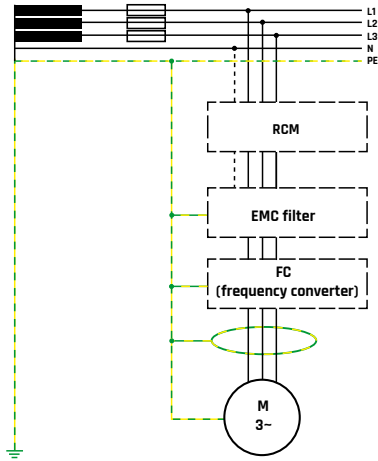

Fig. 7: Connection example with an asynchronous motor

1.4.1. Stationary leakage currents

In its simplest design, the EMC filter consists of LC low-pass filters whose capacitors are connected to the protective earthing conductor using a star configuration. In an ideal network with a strictly sinusoidal voltage, the sum of all capacitive currents through these capacitors is zero. However, as a result of the relatively strong distortions in the mains voltage, the total capacitive current is not equal to zero in practice. This current flows continuously via the protective earthing conductor and is therefore referred to as a stationary leakage current. Significant leakage currents are also generated through the commutation of the B6 bridge connection at the frequency converter input and the commutation of the internal Y capacitors from the intermediate circuit to the PE. If three-phase operated frequency converters are used, a 150 Hz component which depends on the size of the Y capacitors is mainly present. The 150 Hz leakage current generated in this way cannot generally be reduced, even by using additional filter measures. When RCMs with $I_{\Delta n} = 300 \text{ mA}$ are used, this leakage current can therefore result in a high preload. The stationary leakage current is also present when the motor is not running (frequency converter controller lock) and typically contains frequency components of 100 Hz to 1 kHz and frequency components in the resonance frequency range of the EMC filter (typically 2 to 4 kHz).

Very cheap and simple EMC filters with low inductances and large capacitors produce high leakage currents and can result in erroneous signalling by the RCM.

1.4.2. — Use of single-phase operated frequency converters

Single-phase operated frequency converters often have an integrated EMC filter. The filter capacitors in this filter are connected from L to PE and N to PE. This results in significant 50 Hz leakage currents. Therefore, if several frequency converters are used, care must be taken to ensure that they are distributed as uniformly as possible across the three line conductors L1, L2 and L3 in order to compensate for the leakage currents and avoid erroneous signalling by the RCM.

1.4.3. — Variable leakage currents

If the speed of the motor is controlled by the frequency converter, additional frequency components above 1 kHz will occur in the total leakage current. In particular, the switching frequency of the frequency converter (typical values: 2, 4, 8, 16 kHz) and the associated harmonic components are present at a very high amplitude. A long motor cable with an earthed shield has the same effect as a capacitor which is connected to earth and conducts currents at a corresponding frequency to earth together with their harmonic components.

In addition, the frequency components in the resonance frequency range of the EMC filter can increase sharply if the frequency converter switching frequency is approximately the same as or is a multiple of the EMC filter resonance frequency. The EMC filter is stimulated to oscillation by the frequency converter switching frequency and can generate very high leakage currents in the resonance frequency range. Even if the frequency converter is set to a very high switching frequency (e.g. 16 kHz), the frequency converter may significantly reduce its switching frequency automatically at low output frequencies (including when the motor is started up and shut down) in line with the modified modulation method. In a worst-case scenario, the reduced switching frequency may be approximately the same as or a multiple of the EMC filter resonance frequency, causing the leakage current to rise sharply and significantly increasing the risk of erroneous signalling by the RCM. If the motor speed is constant, stationary and variable leakage currents are almost periodic. RCMs respond to these leakage currents with a signal if the currents exceed the response threshold for the monitor at the relevant frequency.

Changes in speed also bring about changes to the variable leakage currents in terms of both frequency spectrum and amplitude, and may potentially result in signalling by the RCM.

1.4.4. ——— **Transient leakage currents**

Note ——— The filters described in this section are generally available as accessories from the manufacturers of the electronic equipment (frequency converters, inverters, etc.).

These manufacturers will also be able to provide further technical details if necessary.

In the event of a switch-off, voltage peaks occur in the network due to inductances in the current paths, and contain very high frequency components due to the steep rising edges. In the event of a switch-on at an unfavourable mains voltage phase angle, the mains voltage spectrum also contains high-frequency components for short periods owing to the rapid rise in voltage. These high-frequency voltage components divert transient currents to earth via the above-mentioned capacitances of the EMC protective measures and this can cause erroneous signalling by RCMs.

If the mains voltage is switched on using non-snap action switches, the three line conductors will be connected at staggered intervals according to the switching speed. If voltage is not being carried by all three conductors, an increased leakage current will flow to earth via the filter capacitors of the EMC filter associated with the conductors which have already been connected. Erroneous signalling due to transient leakage currents can be avoided in many cases by using RCMs with an adjustable response delay. To avoid any inadmissible impairment of the protective function, the response delay is not allowed to exceed certain maximum values. This means that RCMs cannot be arbitrarily "immunised" against transient leakage currents either.

The RCMs in the DRCM A, DCTR A, B, e.Guard RCM F and e.Guard RCM B series all have a response delay of this kind. However, if the duration of the transient leakage currents exceeds the set response delay time, a signal will still be output if the currents are sufficiently high.

1.5. Countermeasures

As made clear in the above chapters, impairment of the intended monitoring function is the price you generally have to pay for making RCMs less prone to erroneous signalling as a result of leakage currents. The following measures are therefore always recommended to keep leakage currents as small as possible.

According to paragraph 531.3.2 of DIN VDE 0100-530 (Selection and erection of electric equipment), the electrical installation must be designed in such a way that the leakage current does not exceed 0.3 times the rated residual current of a residual current operated protective device (RCD). The equivalent of this recommendation should also be observed when using RCMs. Filter measures (both internal filter components and filters installed upstream or downstream of the frequency converter) significantly influence the flow of leakage currents and residual currents in an electrical installation. Depending on the design of the filter measures, higher-frequency currents can flow through the Y capacitors in such a way that they can no longer be detected by upstream RCMs (which is undoubtedly beneficial from the perspective of undesired leakage currents).

To ensure that higher-frequency residual currents (e.g. at the frequency converter switching frequency) are still detected by an upstream RCM, tests should – where necessary – be carried out with artificially generated faults (e.g. using suitable test devices) on the output side of the frequency converter to guarantee signalling in the event of a fault.

1.5.1. Reduction of stationary leakage currents

Many frequency converter manufacturers now offer “low leakage current” EMC filters. Due to the design, this type of filter results in significantly lower leakage currents than with standard filters. The manufacturer's specifications concerning the maximum permitted length of the shielded motor supply cable must be observed.

The E6 EMC filter series from the manufacturer “KEB Antriebstechnik” is a good example of this type of device. The filters in the E6 series only generate very low leakage currents and generally allow the use of Type B or B+ RCMs for a rated residual current of 300 mA.

A four-wire filter can be used in electric networks where there is a neutral conductor. This filter type offers the lowest leakage currents: The main component of the leakage currents is discharged

via the neutral conductor. Additional measures should be taken to ensure that the mains voltage remains as undistorted as possible. Under no circumstances should a single-phase consumer – such as a single-phase operated frequency converter – be connected to the neutral conductor at the output of a three-phase EMC filter (without neutral conductor connection). The asymmetric loading of the filter further increases the leakage currents, greatly impairing the filter effect and meaning that the permitted limits for compliance with the EMC regulations are exceeded by far.

Note — Some controlled dynamic drives prohibit or restrict the use of output filters.
The manufacturer's recommendations must be followed.

If several single-phase operated frequency converters are used, they should be distributed uniformly across all line conductors in order to compensate for the leakage currents.

1.5.2. — **Reduction of variable leakage currents**

The shielded motor supply cable should be as short as possible, with the internal conductors arranged symmetrically and with low impedance. Sinusoidal filters, EMC sinusoidal filters, du/dt filters or output chokes should be installed directly downstream of the frequency converter output (upstream of the motor supply cable). By lowering the edge steepness of the frequency converter output voltage, they significantly reduce leakage currents above 1 kHz on the cable to the motor. Particularly low leakage currents are achieved if a du/dt filter is used. By minimising the edge steepness of the output voltage, output filters also reduce noise emissions, as well as motor bearing currents and high inductance voltages at the motor coils. If several frequency converters with their own (integrated) EMC filter are used, a shared upstream four-wire filter can be used in addition as a means of significantly reducing the variable leakage currents.

1.5.3. — **Additional possibilities for reducing stationary and variable leakage currents**

Mains chokes placed upstream of the EMC filter reduce the current ripple and the associated harmonic components, and also increase the service life of components in the frequency converter. In electrical installations with several frequency converters, a collective filter should be used instead of having individual EMC filters for each frequency converter. The leakage currents of the individual EMC filters are added together. The sum of the leakage currents from

all the individual filters is generally larger than the leakage current from a larger collective filter. The information provided by the filter manufacturer concerning the maximum permitted lengths of shielded motor supply cables must be observed. If several frequency converters are used in an electrical installation, care should be taken to avoid starting them up at the same time. If a controller enable is issued for several frequency converters at once, this may temporarily result in high leakage currents which are added together, potentially resulting in erroneous signalling by the RCM.

1.5.4. **Reduction of transient leakage currents when switching an electrical installation with electronic equipment on and off**

As mentioned above, compliance with the EMC regulations means that filters must be used if electronic equipment is installed. For example, in the case of a three-wire standard EMC filter, these filters contain a star connection of three capacitors to earth. If an RCM with a switch-off device is used, the switch-off device may include a simple sequential circuit without snap-action operation. The closing and opening of the individual current paths over time depends on the switching speed of the operator and, under certain circumstances, can result in a time difference of 10 to 40 ms. The star point of the three capacitors is no longer balanced during this time. A significant capacitive leakage current may flow via the protective earthing conductor, thereby triggering a signal or switch-off if a switch-off device is being used. Connection and disconnection should therefore only be performed using an additional fast-acting switching device (e.g. a disconnecter with snap-action operation or an all-pole switching contactor).

In electrical installations with a very large number of frequency converters, switch-off may occur in exceptional cases, particularly during switch-on, even if a fast-acting switching device is used. In such cases, the uncharged filter capacitors lead to very high leakage currents flowing for a period which exceeds the maximum permissible switch-off time. A collective EMC filter for several frequency converters may also reduce the high switch-on leakage current significantly.

Note — In the case of RCMs, please be aware that this effect may, under certain circumstances, trigger an erroneous signal or switch-off if you are using an RCM with a switch-off device.

Example — The resonance frequency of the EMC filter is 2.1 kHz. If a switching frequency of 2 kHz were chosen for the frequency converter, it would be very close to the resonance frequency and could result in very high leakage currents. Even a switching frequency of 4 kHz could still lead to high leakage currents, since this is almost twice the resonance frequency. Higher switching frequencies and, in particular, non-multiples of the resonance frequency (e.g. 6 kHz, or preferably 7 kHz) will make the EMC filter less likely to oscillate, in turn reducing the high leakage currents associated with this. Further details regarding the resonance frequency of the EMC filter and the potential deactivation of automatic changes to the switching frequency of a frequency converter at low output frequencies should be requested from the manufacturers of the equipment where necessary.

1.5.5. — **Avoiding natural oscillation (resonance) by an EMC filter**

As a rule, different switching (chopper) frequencies can be selected for electronic equipment such as frequency converters. In a worst-case scenario (e.g. a long shielded motor supply cable), the switching frequency may result in the oscillation of an upstream EMC filter and therefore excessively high leakage currents, which then trigger a signal by the RCM. In this case, the switching frequency of the frequency converter must be changed. In addition, it is essential to observe the maximum permitted length for the shielded motor supply cable prescribed by the frequency converter or filter manufacturer.

Note — These integrated filters often restrict the maximum length of the shielded motor supply cable to just 5 to 10 m. The EMC conformity declarations made in the frequency converter operating instructions (e.g. EN 55011, Class A, B) are generally only valid for these relatively short cable lengths. Cable lengths of 50 to 100 m are often also specified. However, such cable lengths do not generally relate to EMC conformity, but to the maximum permitted capacitive load (capacitance of the shielded motor supply cable) which can be supported without difficulty by the frequency converter's output stage.

There is an increased risk of erroneous signalling if the frequency converter switching frequency is approximately equal to or is a multiple of the EMC filter resonance frequency. Many frequency converters reduce their switching frequency automatically at low output frequencies (typically below approximately 20 to 30 Hz, and also when the motor is started up and shut down). Higher switching

frequencies (including higher-order multiples of the resonance frequency) generally minimise the risk of a tendency to oscillation in the EMC filter.

1.5.6. — Inductive leakage currents

As mentioned above, leakage currents are generally capacitive. However, inductive leakage currents are not unusual, and are particularly likely to occur in electrical installations with very high currents. They tend to occur in the lower frequency range.

Example — Electrical installation with three-phase operated frequency converter and EMC input filter and motor with conventional shielded four-core motor supply cable (U, V, W, N/PE) with a length of approx. 50 m. The machine frequency is 20 Hz and the motor current per phase is approx. 200 A. As a result of the asymmetric internal design of the four-core motor cable, an inductive injected leakage current of several hundred mA may occur at a frequency of 20 Hz in the N/PE current path. Shielded motor supply cables that have the inner conductors arranged symmetrically and with low impedance should therefore be used wherever possible. This significantly reduces both inductive and capacitive leakage currents.

1.5.7. — Changes to existing electrical installations

If changes are made to an existing electrical installation which has already been measured for EMC purposes (for example, if changes are made to the filter measures or to the switching frequency of a frequency converter), EMC-related measurements must generally be repeated to ensure that the installation still complies with the relevant EMC guidelines that apply. Checks should also be carried out to ascertain whether reliable signalling by the RCM is still guaranteed in the event of faults on the output side of the frequency converter.

1.6. — Integrated EMC filters

Many frequency converters already feature an internal EMC input filter, which means there is no need for an external one. Longer supply cables result in magnetic saturation of the EMC filter choke as a result of the increase in asymmetric capacitive currents. The consequence of this is extremely high leakage currents and filter resonance.

A saturated filter choke renders the filter ineffective, meaning that the permitted limit values of the relevant EMC guidelines are exceeded by far and the frequency converter becomes a frequently unnoticed emitter of significant interference for other consumers. If a frequency converter with an integrated EMC filter is used in conjunction with a long shielded motor supply cable (>10 m), the integrated filter must be deactivated wherever possible and an external EMC filter installed which is suitable for operation with long motor supply cables. It may be necessary to carry out EMC measurements on the entire electrical installation in order to determine which filter is suitable.

Our quality objective is to supply customised special solutions that are tailored to meet individual customer requirements.

Jann Eilers, Technical Design



Part II

What is a residual current monitor (RCM) and what are the different types?

2. Why use an “RCM”?

2.1. ——— What is a residual current monitor (RCM)?

A residual current monitor (RCM) records and monitors residual currents in electrical installations. Although this still involves evaluating a residual current, the difference compared to RCDs (residual current operated devices) is that an RCM does not usually have a switch-off device like the one found on an RCCB that consists of a tripping relay and latch with main switching contacts.

2.2. ——— What components make up an RCM?

An RCM consists of a residual current transformer and an evaluation unit that evaluates the residual currents detected by the residual current transformer. For special applications, the RCM can be supplemented by a switch-off device. As with RCDs, a distinction is likewise drawn here between the different types of residual current transformers and evaluation units. Firstly, there are different tripping characteristics (AC, A, F, B, B+) and different response thresholds available for the residual current (300 mA, 500 mA, and so on). The appropriate tripping characteristic and response threshold can therefore be selected for the RCMs in order to monitor the residual currents that are to be expected (which vary according to the nature of the electrical equipment being used).

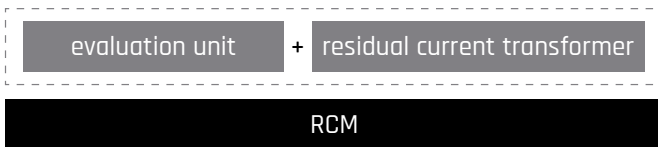

Fig. 8: Representation of an RCM with a residual current transformer and evaluation unit

2.3. RCM with switch-off device

An RCM essentially consists of a residual current transformer and an evaluation unit. These components allow the residual current present on an electrical installation at that moment to be visualised and signalled. In most cases, the evaluation unit features an optical display for showing the current value of the residual current. In addition, the evaluation unit has one or more potential-free contacts.

These contacts can be freely configured for any level of residual current. As a result, when the relevant threshold is exceeded, a signal can be forwarded to an additional evaluation system, such as a mini controller or PLC.

RCMs are only able to signal when the installation is in a critical condition. A sequence of actions (to be defined by the relevant organisation) must then be triggered on the basis of this signal. However, in many cases – e.g. in facilities at risk of fire – a signal is not always sufficient. If the risk of fire cannot be reliably ruled out simply by triggering an alarm to signal that the installation is in a critical condition without actually performing a switch-off, then the RCM must be capable of performing one in order to avoid the risk of fire and damage to property. To achieve this, an additional switch-off device is required, e.g. in the form of a circuit-breaker with an undervoltage release that can be tripped by a signal contact if the limit values preset for the evaluation unit are exceeded, thereby switching off the installation. Figure 9 shows an example layout for an RCM used in combination with a switch-off device with a disconnection feature.

Note For installations with a nominal current of up to 125 A, Doepke offers a switching device with a disconnection feature in the form of its DHS-NA all-pole main switch, which enables switch-off when used in conjunction with products from the DCTR and e.Guard RCM series. This is a four-pole main switch with an integrated emergency switching-off function that is capable of switching off the circuit when triggered by the alarm from the RCM.



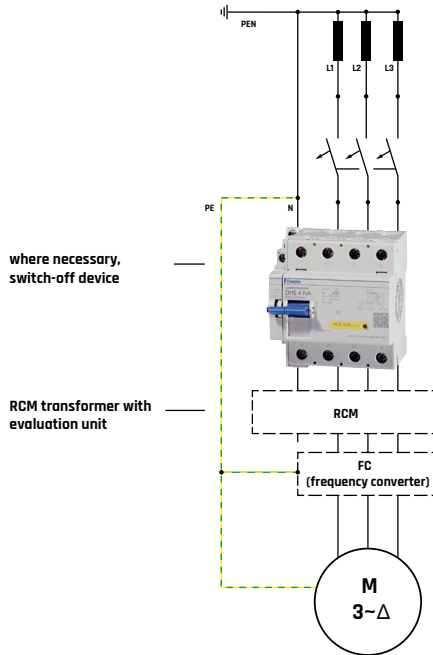

Fig. 9: Illustration of an RCM featuring a residual current transformer and evaluation unit, with switch-off performed by the upstream DHS-NA all-pole main switch

2.4. Different types of RCM

In light of the different residual currents that are to be expected on electrical installations and the nature of the electric equipment installed within them, a distinction is drawn between Types AC, A, F, B and B+ for RCMs in exactly the same way as for RCDs. In Germany, Type AC has been banned since as far back as the mid-1980s. Therefore, it will not be explored in any further detail here. Nevertheless, Type AC is still permitted under some foreign installation regulations and so caution is advised. To help you better understand the differences between them, the four different types are described in more detail below together with their applications.

2.4.1. RCM Type A

Type A RCMs are designed for Type A residual currents, i.e. they are solely intended to respond to AC residual currents and pulsating DC residual currents at their rated frequency, or in other words the mains frequency. The response thresholds for residual currents with other frequencies are not defined. Therefore, these RCMs will not necessarily detect a fault in the event of smooth DC residual currents or higher-frequency AC residual currents. Too large a direct component in the residual current can even interfere with the detection of AC residual currents whose frequency does match that of the mains frequency.

2.4.2. RCM Type F

Type F residual current monitors are mixed frequency sensitive. They respond to pulsating residual currents, AC residual currents and residual currents with mixed frequencies not equal to 50 Hz. These can occur, for example, when using single-phase operated frequency converters without a PFC stage.

2.4.3. RCM Type B

Many types of power electronics equipment – such as uninterrupted power supplies, photovoltaic inverters or frequency converters – generate a bipolar square wave voltage (clocked direct voltage) from smooth direct voltages, either internally (DC link) or directly as an output voltage; this bipolar square wave voltage modulates the sinusoidal output voltage with the desired output frequency as a result of pulse width control. This means, for example, that frequency converters may not only cause residual currents at mains frequency and smooth DC residual currents in the event of a fault, but also residual currents with a frequency mix made up of the clock frequency plus its harmonic components and the output frequency. In order to guarantee comprehensive residual current detection even if such equipment is used, the RCM used for this purpose must therefore also be capable of reliably detecting smooth DC residual currents and AC residual currents at these frequencies.

In practice, this means that RCMs must respond so sensitively to residual currents at all frequencies from 0 Hz up to the highest conceivable clock frequency of the equipment that the intended level of detection is guaranteed not only at the rated frequency, but across the entire frequency range. This is the only way to avoid miscalculating the level of residual current detection provided when selecting an RCM on the basis of its rated residual current. However, power electronics equipment frequently causes high leakage currents, which may also be erroneously detected by RCMs. The response threshold frequency response of the RCM should therefore be only slightly below the limit necessary to achieve the intended level of residual current detection. RCMs with a Type B response characteristic meet these requirements to a greater or lesser extent, depending on the standard according to which they have been designed.

Note — The detection ranges of AC-DC sensitive RCMs differ considerably from one manufacturer to another in terms of their tripping threshold and the frequency ranges covered. Depending on the design and manufacturer, Type B RCMs are capable of signalling AC residual currents up to 100 kHz.

2.4.4. — RCM Type B+

The difference between Type B+ and Type B RCMs is that the former support a wider frequency range. Under the relevant standards, Type B RCMs must be capable of detecting currents up to a frequency of 1 kHz. By contrast, the standards stipulate that Type B+ RCMs should be able to detect AC residual currents all the way up to a frequency of 20 kHz.

2.5. — Identification of the different RCM types

The different RCM types are identified by the following symbols, which are based on the various types of residual current operated protective device (RCDs).



Type AC



Type A (sensitive to pulsating currents)



Type F (mixed frequency sensitive)



Type B (AC-DC sensitive)

2.6. Protection target and degree of protection of an RCM

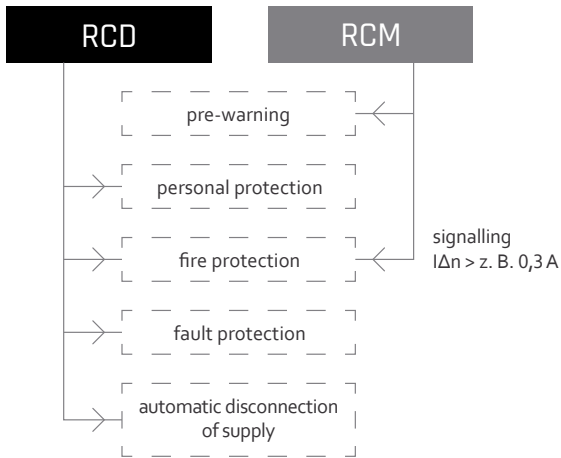

Fig. 10: compares the protection targets achieved and the degree of protection of an RCD and an RCM (without a switch-off device).

Note — At this point, it is important to state that an RCM (even one with a switch-off device) is not approved for automatic switch-off protection according to DIN VDE 0100-410 and additional protection (personal protection). However, a correctly parameterised RCM with an optional switch-off device is more than adequate for preventive fire protection.



Part III

Evaluation of residual current measurement data



3. Evaluation of residual currents

3.1. ——— RMS evaluation of residual currents

Residual currents are usually evaluated as a sum signal that represents a root-mean-square value (AC) for the residual current transformer frequencies within the detection range. The AC-DC sensitive versions of Type B also evaluate a direct current component (DC) in addition to this.

Thus, with RMS value detection, a single root-mean-square value is calculated continuously to represent the sum of the temporal residual currents within the RCM's detection range.

Consequently, it is not possible to draw any conclusions about any of the individual frequencies that contribute to the overall root-mean-square value.

In cases where a high preload is generated by capacitive leakage currents, it also becomes much more difficult to allow for a high-impedance resistive residual current in the event of a fault.

Example ——— The total leakage current from an installation during operation is 300 mA. An RCM is used with the aim of detecting an emerging fault at an early stage (e.g. an insulation fault). Due to the presence of moisture, a fault initially characterised by high resistance is produced that involves a residual current of 30 mA to the protective earthing conductor.

The RCM now identifies the geometric sum of the residual currents relative to the 50 Hz mains frequency. Given that the preload is generated by a capacitive leakage current made up of different frequency components, and the residual current is purely resistive, the total residual current is calculated as follows:

$$I_{\Delta} = \sqrt{I_{\text{ableit}}^2 + I_{\text{fehler}}^2}$$

$$I_{\Delta} = \sqrt{(300 \text{ mA})^2 + (30 \text{ mA})^2}$$

$$I_{\Delta} = 301,5 \text{ mA}$$

This means that the summation current transformer is only able to identify a change of approx. 1.5 mA in the total residual current in the event of a 30 mA residual current. To overcome this problem, the installation location for the RCM must be carefully selected so

that the evaluation processes are coordinated in terms of the preload generated by the operational leakage currents and the necessary measurand.

Example — By way of an example, Figures 11 and 12 below show the operational leakage current behaviour of a piece of electronic equipment (e.g. frequency converter) when operated in an electrical installation within the frequency and RMS value ranges. The measurement process was carried out using the DRCA-1 residual current analysis software and is therefore not comparable to detection with an RCM.

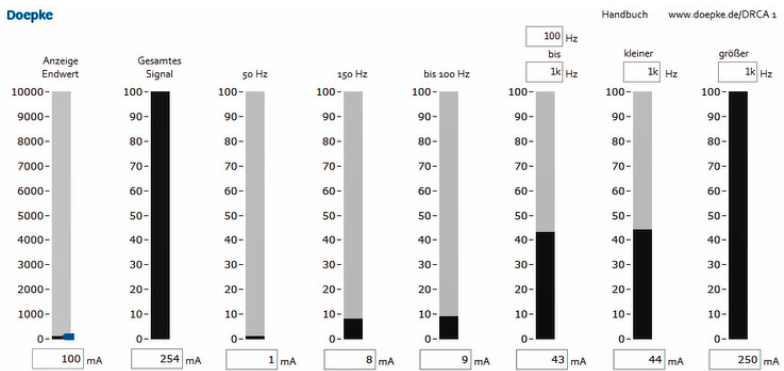

Fig. 11: Residual current represented as a root-mean-square value in various frequency ranges

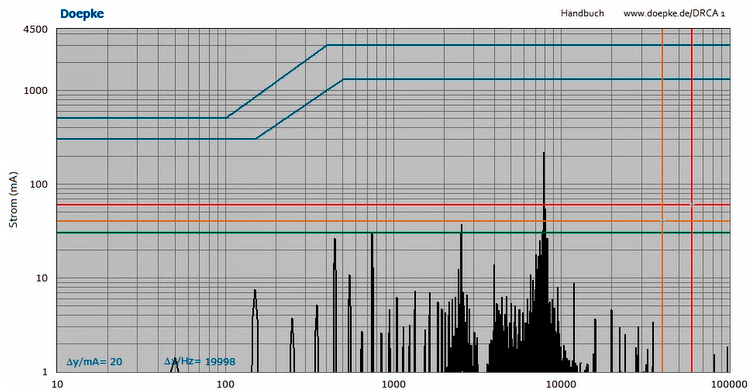

Fig. 12: Residual current as a Fourier analysis within the frequency range



Here, you can see that the sum of the operational leakage currents is made up of a large number of individual frequency components. Figure 13 is characteristic of operational leakage currents in that it shows four different frequency ranges.

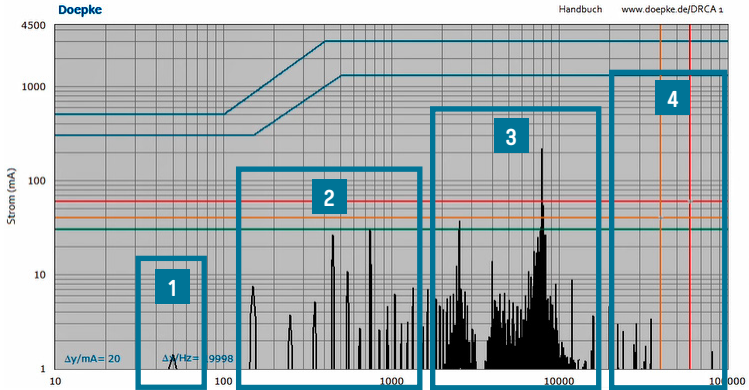

Fig. 13: Residual current divided into four individual frequency ranges

Frequency range	Frequency	Possible causes	Comments
1	50 Hz	Single-phase electronic equipment, single-phase frequency converters	If a frequency of 50 Hz is present in the leakage current, it is essential to rule out the possibility of a residual current having been caused by an insulation fault on the electrical installation.
2	100 – 1 kHz	EMC filter on three-phase electronic equipment, e.g. frequency converter	-
3	2 – 20 kHz	Clock frequencies and their harmonic components	-
4	> 20 kHz	Inadequately dimensioned EMC measures	-

Table 1: Overview of the four frequency ranges together with the possible causes

With RMS value evaluation of the residual current, the root-mean-square value is generated for all the frequencies within the detection range. The root-mean-square value identified during this process is shown by the channel highlighted below in Figure 14.

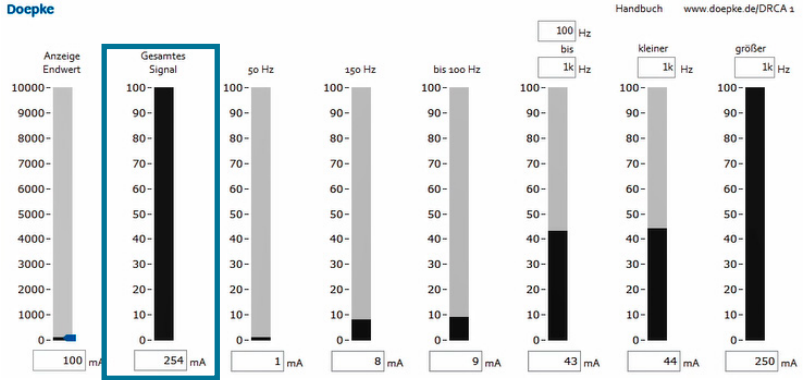

Fig. 14: Residual current represented as a root-mean-square value

Thus, this example RMS value representing the total leakage current is made up of a large proportion of frequency components > 1 kHz. A smaller proportion is accounted for by frequencies ranging between 100 Hz and 1 kHz. Due to the generation of the RMS value by the RCM, it is not possible to draw any conclusions about the individual frequency components within the residual current. In cases where a high preload is generated by capacitive leakage currents, it also becomes much more difficult to allow for a high-impedance resistive residual current in the event of a fault.

Note — The leakage current behaviour of single-phase and multi-phase electronic equipment depends on many different factors. Consequently, it is not possible to make any general statements about the kinds of leakage currents that are to be expected. Instead, each application must be considered individually in situ. Figures 11 to 14 merely show an example leakage current for a piece of electronic equipment.

3.2. Frequency-selective evaluation of residual currents

When the residual current is evaluated using the frequency-selective method, individual frequency ranges are identified separately in addition to the residual current RMS value for all frequencies. Consequently, both the level of the residual current and its individual frequency components can be monitored.



The larger volume of information obtained as a result offers considerable advantages when monitoring electrical installations. In this case, possible causes can be stated directly on the basis of the residual currents and their individual frequencies, as well as the frequency ranges involved.

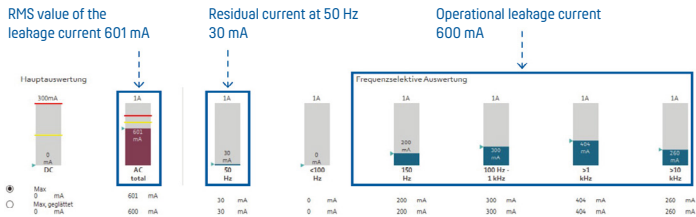

Fig. 15: Frequency-selective evaluation of the residual currents with e.Guard RCM B and allocation of the individual frequencies

In addition, frequency-selective evaluation can be used to achieve an optimum level of protection because it allows individual alarm thresholds to be set for the various frequencies or frequency ranges. The additional information about the various frequency components is also helpful in the context of troubleshooting. The frequency-selective residual current transformers in the e.Guard RCM F and e.Guard RCM B series feature eight different frequency channels that can be individually adjusted for the operational leakage behaviour of the installation, thereby providing optimum protection and a much higher volume of information. In the case of the e.Guard RCM B series, the frequency ranges shown in Table 1 (p. 31) are infinitely adjustable via the software. This allows you to set a maximum residual current of 30 A per channel for frequency evaluation (AC) and a maximum residual current of 3 A for direct current evaluation (DC). Table 2 below shows the various evaluation channels that are available on the frequency-selective e.Guard RCM B transformer.

Frequency	Maximum adjustment range	Alarm thresholds
DC	3 A	2
AC total (0.05 Hz–100 kHz)	30 A	2
50 Hz	30 A	2
< 100 Hz	30 A	2
150 Hz	30 A	2
100 Hz–1 kHz	30 A	2
> 1 kHz	30 A	2
> 10 kHz	30 A	2

Table 2: Frequency ranges of the e.Guard RCM B and maximum adjustment range

Part IV

Applications and areas of use for RCMs

4. APPLICATIONS AND AREAS OF USE OF RCMs

4.1. ——— RCM applications and application areas (examples)

The areas described below only account for some of the applications. The principles described can be transferred across to many other application areas as well.

4.2. ——— Fire protection and protection of property (facilities at risk of fire)

RCMs that meet the requirements of DIN EN IEC 62020-1 can be used to provide protection against fire risks if residual current operated protective devices (RCDs) cannot be utilised for technical reasons, e.g. because the operating current of the circuit you want to protect exceeds the highest rated current of any available RCD.

In such cases, the residual current monitors (RCMs) must be operated in conjunction with a circuit-breaker that meets the requirements of DIN EN 60947-2 and switches off the circuit being monitored. Furthermore, the supply voltage of the RCM must be independent of the circuit being monitored.

4.3. ——— Fire protection and protection of property (facilities at risk of fire in agriculture)

The use of frequency controlled ventilation systems in agricultural contexts goes hand in hand with tougher requirements for the protection technology. For fire protection reasons, the risks that are posed by high residual currents must be minimised. That is why an RCD with a maximum rated residual current of 300 mA must be installed in areas at risk of fire, including any electric equipment that has a fixed connection. However, an RCD cannot issue a prior alarm to tell you that the condition of the installation is deteriorating, thereby depriving you of advance information. If the maximum rated residual current is exceeded, an RCD trips and isolates the ventilation system from the power supply system by disconnecting all poles.

This creates a problem if a ventilation system failure goes undetected and there is no regulated fresh air supply for a prolonged period as a result. Switching off the circuit due to a high residual current directly conflicts with the need to maintain a continuous supply of fresh air. By using an RCM with a switch-off device not only can the necessary fire protection be achieved but you can also obtain the advance

information that is so important in this scenario. The prior signal issued by the RCM allows you to take action before the installation is definitively switched off.

4.4. Repeated insulation testing of cables and lines

Another RCM application relates to the repeated insulation tests that are carried out on cables and lines in electrical installations.

According to DIN VDE 0105-100:A1/2017-06 and DIN VDE 0100-600:2017-06, it is necessary to check the insulation resistance of all active conductors in relation to the protective earthing conductor and the insulation resistance of all active conductors in relation to one another as part of the repeated testing of electrical installations. This poses several challenges. Firstly, this type of test requires the installation to be switched off and, secondly, the increased use of electronic equipment corrupts the insulation measurements to such an extent that no reliable statements can be made concerning the insulation resistance. In a worst-case scenario, the process of measuring the insulation resistance can even damage sensitive electronic equipment beyond repair.

In the current version of DIN VDE 0105-100: A1/2017-06, sub-section 5.3.3.101.0.2, the normative situation for this domain has changed. According to the standard, the use of a fully functioning residual current monitor pursuant to DIN EN IEC 62020-1 or insulation monitoring device pursuant to DIN EN 61557-8 in combination with constant monitoring of the electric circuits eliminates the need for periodic insulation testing.

4.5. IT infrastructures

Another application area for RCMs concerns data systems and information technology. Server rooms often also contain plug and socket outlets that can be operated by non-specialists and which – according to the requirements of DIN VDE 0100-410 and DIN VDE 0100-530 – have to be protected by an RCD with a rated residual current of max. 30 mA in the interest of providing additional protection (personal protection). These sockets are used to operate servers and other items of electrical equipment, where it is not just a question of providing extensive protection for the equipment itself but also of ensuring a high level of system availability. In the case of equipment with a fixed connection or installations in addition to the RCD, using an RCM with continuous monitoring allows you to assess the current

condition of the electrical installation at any time – along with the equipment connected to it – in terms of the associated operational leakage currents and the condition of the cable and line insulation.

To increase the level of system availability and allow for preventive maintenance, continuous monitoring with an RCM can likewise be used in situations that involve plug and socket outlets that cannot be operated by non-specialists and when there are additional organisational regulations in place. Furthermore, thresholds can be set so that RCMs issue a pre-warning, thereby providing you with advance information. DIN VDE 0105-100:A1/2017-06 states that there is no longer any need for repeated insulation testing in this scenario either. This would involve switching off the servers and other equipment, which would not be desirable in most cases.

4.6. Preventive maintenance

Thanks to the advance information generated by the continuous residual current monitoring, deteriorations in the insulation resistance of cables and lines can be detected at a very early stage. The different thresholds that are used to signal rising residual currents within an electrical installation allow you to respond early to changes within the installation. This means that information is generated about any deterioration in the condition of the insulation before the installation gets switched off due to impermissibly high residual currents, e.g. when an insulation fault slowly develops on a cable or line because of the presence of rodents or moisture. Having this advance information at your disposal allows you to plan and carry out maintenance work in a targeted way in relation to specific installations. In turn, downtimes and production losses can be prevented.

Moreover, continuous residual current monitoring enables you to identify changes and defects in EMC filters within electronic equipment and any resulting changes in the leakage current from an installation. Once again, the advance information allows you to respond to the relevant installation based on the specific situation. Frequency-selective evaluation of the residual current, e.g. with the e.Guard RCM F or e.Guard RCM B, makes it possible to draw conclusions about changes that must have occurred within the installation in each case.

Figure 15 compares the behaviour of an RCD and an RCM in response to a slowly developing residual current. In addition, it shows the alarm thresholds of an RCM in yellow and red.

4.7. Photovoltaic and wind power plants, and pumping and lifting stations

A high level of system availability is also required for remote installations such as photovoltaic systems, wind power stations or pumping and lifting stations. This high level of system availability can be maintained by ensuring continuous servicing and maintenance. Once again, preventive maintenance measures can be implemented based on the additional information that an RCM is able to provide about a deterioration in the condition of the installation. In this way, installation failures and unplanned downtimes can be minimised.

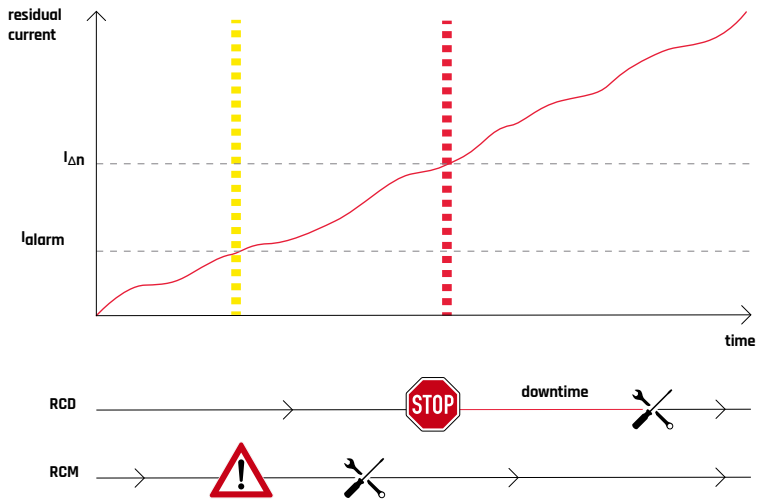

Fig. 16: Comparison between RCD and RCM

4.8. Summary

In summary, RCMs can be used in lots of different areas – such as industry, data processing and information technology – as well as for fire protection in facilities at risk of fire. RCMs are absolutely ideal for the preventive maintenance of electrical installations when a high level of system availability also needs to be factored in. Breaking the detected residual current down into several frequency bands can be particularly helpful when assessing the condition of an electrical installation.

The use of RCMs is not permitted for the purpose of implementing the “automatic disconnection of supply” protective measure or for providing additional protection in accordance with DIN VDE 0100-410. As a general rule, an RCM must not be used as a substitute for any RCD that needs to be provided. An exception can be made in special cases where, for example, switch-off by an RCD could lead to a further hazard (e.g. the sudden slow-down of quickly rotating machine tools), although this is also conditional upon a risk analysis.

Part V

References to the use of RCMs in standards

5. REFERENCES TO RCMS IN STANDARDS

5.1. ——— **DIN VDE 0100-600:2017-06**

Low-voltage electrical installations – Part 6: Testing

Clause 6.4.3.3.: It is not possible to dispense with the insulation testing. The insulation test must be carried out before the electrical installation is connected and put into operation. The test should be carried out step by step, not on completion of all the work. The insulation resistance must be measured between all active conductors and PE. For this purpose, the active conductors are allowed to be connected to one another.

5.1.1. ——— **DIN VDE 0105-100/A1:2017-06**

Operation of electrical installations – Part 100: General specifications; Change A1: Periodic verification

Section 5.3.3.101.0.2 states that if an electric circuit is continuously monitored by a residual current monitor (RCM) pursuant to DIN EN IEC 62020-1 or an insulation monitoring device (IMD) according to DIN EN 61557-8, measurement of the insulation resistance can be dispensed with. It must be ensured in such cases that the monitoring devices are fully functional.

Section 5.3.3.101.0.4 also states that, for electrical installations that are subject to an effective management system in normal operation for preventive maintenance, periodic testing can be replaced by an appropriate system of continuous monitoring in combination with ongoing maintenance by electrically skilled persons.

5.1.2. — **Guidelines for testing electrical installations - SK 3602**
Testing guidelines according to clause SK 3602 -
Information for recognised electrical experts

SK 3602 - Insulation resistance measurement: For each distribution board, at least 50% of all final circuits should be tested in this way. If this test cannot be performed for operational reasons or cannot be carried out to an adequate extent, this must be noted on the inspection certificate. The expert must enquire as to whether special alternative measures have been agreed between the insurance provider and the policyholder. Your attention is drawn to inspection certificate VdS 2229 in this regard.

5.1.3. — **DGUV regulation 3:1997-01**
Accident prevention regulation, electrical installations and equipment

Section 5 Tests: The employer shall ensure that the proper condition of electrical installations and equipment is tested: prior to commissioning, and prior to restarting following modification or repair, by an electrically skilled person or under the responsibility and supervision of an electrically skilled person; and at specific intervals. The intervals shall be selected such that defects which are to be anticipated are detected in good time. The electrical rules relating to testing shall be observed during testing.

A test log in which specific entries are made shall be maintained where so required by the statutory accident insurance institution. Testing prior to commissioning in accordance with Paragraph 1 need not be performed should the employer have obtained confirmation from the manufacturer or erector that the electrical installations and equipment are engineered in compliance with the provisions of the present accident prevention regulation.

Installation/equipment	Test interval	Form of testing	Tester
Electrical installations and stationary equipment	4 years	For proper condition	Electrically skilled person
Electrical installations and stationary electrical equipment in commercial premises, rooms and installations of special kinds (in the sense of DIN VDE 0100 Group 700)	1 year		
Protective measures involving earth-leakage protection equipment in temporary installations	1 month	For effectiveness	
Earth-leakage (residual-current, voltage-operated) circuit-breaker – in permanent installations – in temporary installations	6 months Each working day	For proper operation, by actuation of the test facility	User

Table 3: Regular tests of stationary electrical installations and equipment

The requirements for stationary electrical installations and equipment are, for example, also satisfied when they are continuously monitored by an electrically skilled person. Stationary electrical installations and equipment are deemed to be continuously monitored when they are continually:

- maintained by electrically skilled persons; and
- tested by means of instrumentation measures in the course of operation (such as by monitoring of the insulation impedance).

5.1.4. ——— **Damage prevention guidelines - VdS 3501:2021-10** **Insulation protection in electrical installations with electronic equipment - RCD and frequency converters**

Section 5: If a residual current operated protective device (RCD) cannot be used, e.g. because the operating current of the circuit you want to protect exceeds the highest rated current of the RCD, an alternative option is to use an AC-DC sensitive residual current monitor (RCM) or MRCD with switch-off device (e.g. a circuit-breaker) plus a CBR.

Provided that the operational leakage currents are as constant as possible, the use of an RCM, CBR or MRCD is beneficial because you can adjust the response sensitivity of the RCM, CBR or MRCD to allow for these.

However, RCMs are not permitted for the purpose of implementing the "Protection by automatic disconnection in the event of a fault" protective measure in accordance with DIN VDE 0100-410.

5.1.5. ——— **DIN VDE 0100-530:2018-06** **Low-voltage electrical installations - Part 530: Selection and erection of electrical equipment - Switchgear and controlgear**

532.3 Residual current monitors (RCMs) for protection against fire risks in IT systems

Section 532.3 states that, in IT systems, residual current monitors (RCMs) pursuant to DIN EN IEC 62020-1 in combination with a system that is suitable for isolation can be used as an alternative to residual current devices (RCDs) pursuant to 532.2. This also requires the area to be monitored by electrically instructed or electrically skilled persons. The residual current monitors (RCMs) must be installed at the start of the final circuit, and the tripping residual current must not exceed 300 mA. The RCM must provide acoustic and visual signals for the purpose of raising the alarm. Priority must be given to observing the requirements of DIN VDE 0100-410, 411.6.3.1 for insulation monitoring devices (IMD).

538.4 Residual current monitors (RCMs)

538.4.1 General

Residual current monitors (RCMs) must conform to DIN EN IEC 62020-1. It is recommended that residual current monitors (RCMs) be installed at the start of the outgoing circuits. A residual current monitor (RCM) continuously monitors the downstream installation or its components for leakage and earth fault currents. Its purpose is to inform the user of how high the currents are in the installation component being monitored. If a residual current operated protective device (RCD) is connected upstream of the residual current monitor (RCM), it is recommended that the operating residual current of the residual current monitor (RCM) be set to a level no higher than half the rated residual current $I_{\Delta n}$ of the residual current operated protective device (RCD). Residual current monitors (RCMs) have to generate a visual and/or acoustic signal throughout the entire time that the fault remains present. Residual current monitors (RCMs) are not suitable for protection against electric shock.

Part VI

Overview of RCM series and types

6. Overview of RCM series and types

6.1. ——— DRCM Type A

These devices are characterised by a large number of usable summation current transformers and therefore also many different conductor cross-sections/rated currents. The bar display indicates the residual current present at that moment. The alarm is signalled as soon as a fixed response threshold is reached. A ten LED display on the front of the device housing indicates the level of the instantaneous residual current and when the response thresholds are exceeded. A faulty connection to the external residual current transformer is immediately indicated by the alarm LED through a flashing pattern and by the activation of the signal contacts. The adjustable response delay in the range from 0.1 s to 1 s (in increments of 100 ms) makes it possible to prevent a response to brief residual current pulses, e.g. as a result of lightning strikes and switching overvoltages. This approach also allows selectivity to be achieved for series-connected devices, thereby making the fault localization process easier. Two independent, potential-free changeover contacts make it possible to forward the alarm to optional indicator panels, indicator lights, acoustic signalling devices, touch panels, PLCs, mini controllers, and so on. Type A residual current monitors detect sinusoidal AC and pulsating DC residual currents and are designed for a rated frequency of 50 Hz at a rated voltage of 230/400 V. The devices in the DRCM Type A series can be set to five different levels of rated residual current: 30, 100, 300, 1000 and 3000 mA.

The associated DCT residual current transformer is available in a choice of four internal diameters: 20, 35, 70 and 105 mm.

Fig. 17: DRCM A



6.1.1. ——— Intelligent DCTR transformers

The DCTR residual current transformer with integrated evaluation unit from Doepke detects frequencies from 0 to 100 kHz with 100% reliability, far exceeding the requirements set out in the standards for residual current detection. The easy to install devices are available as Type A (sensitive to pulsating and alternating currents) or Type B (AC-DC sensitive) residual current transformers.

When it comes to evaluating the residual currents, there are different transformer types available and differences in terms of the associated evaluation unit and data transfer method.

6.1.2. ——— The DCTR Type A and DCTR Type B series

The devices in this series evaluate residual currents of up to 300 mA, which are represented using a 4–20 mA standard interface. From the perspective of operational leakage currents, they are therefore ideal for providing comprehensive fire and installation protection. A potential-free contact – which switches at approximately 50% of the residual current – can be used to signal an alarm or switch off the installation. Thanks to the 4–20 mA standard interface, the devices can be easily integrated into existing installations with analogue evaluation equipment (mini controllers, process control systems, programmable logic controllers, etc.). To accommodate different rated current strengths for the circuit being monitored, Type A pulsating current-sensitive and AC current-sensitive transformers are available with four different internal diameters (20 mm, 35 mm, 70 mm, 105 mm). In the case of the Type B AC-DC sensitive variants, there is a choice of three internal diameters (20 mm, 35 mm, 70 mm).



Fig. 18: DCTR B-X-Hz-PoE

6.1.3. e.Guard RCM B series

The e.Guard RCM B series takes residual current detection to the next level by adding a frequency-selective transformer that relies on a PoE (Power over Ethernet) interface for data transfer. As well as allowing data to be exchanged with the Doepke e.Guard system, the PoE interface also supplies the power to the transformer. Widely established data transmission protocols are supported, which makes connection to and integration into other systems much easier. The Doepke e.Guard system is structured across five levels and is used for visualising, parameterising, storing and logging residual current data. The e.Guard RCM B is additionally capable of evaluating residual currents in terms of their frequencies thanks to the freely adjustable tripping thresholds on eight different frequency channels (DC, AC, 50 Hz, < 100 Hz, 150 Hz, 100 Hz – 1 kHz, > 1 kHz, > 10 kHz). Each of these frequency channels can detect a maximum residual current of 30 A as well as a DC current of up to 3 A. The two potential-free and freely parameterisable contacts can, for example, be used to generate alarms or switch-off signals. In addition, thanks to the integration in the Doepke e.Guard system, it is possible to send email notifications when preset thresholds are exceeded or to send monthly reports for the purpose of documenting residual current data. Figure 18 below shows an example setup of the RCM network using the e.Guard RCM B and data evaluation with the e.Guard gateway. Table 4 offers an overview of the functions supported by the devices in the DCTR and e.Guard RCM B series.

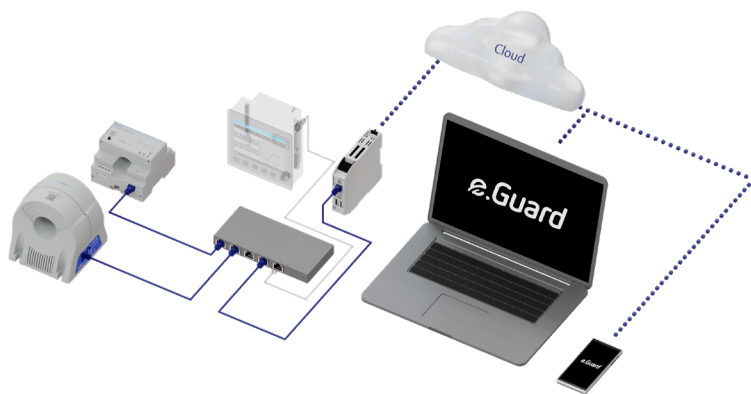

Fig. 19: Setup of e.Guard RCM with network switch and e.Guard gateway



TECHNOLOGICAL CHANGE ALLOWS US TO MAKE
ELECTRICITY EVEN SAFER TO USE.



Overview of residual current monitors

Transformer Type	DCTR A Type A	DCTR BNK Type B	e.Guard RCM F	e.Guard RCM B
Interface	4–20 mA		Ethernet	
AC-DC sensitive up to 100 kHz, smooth DC residual currents		■		■
Fire protection at 50 Hz	■	■	■	■
Fire protection up to 100 kHz		■	■	■
One potential-free contact	■	■	■	■
Two potential-free contacts			■	■
e.Guard system			■	■
Installation can be switched off with an additional switch-off device	■	■	■	■
Test button on the device	■	■	■	■
Connection of an external test key	■	■	■	■
Remote test via e.Guard system			■	■
complies with product standard DIN EN IEC 62020-1	■	■	■	■

Table 4: Overview of DCTR and e.Guard RCM series

Part VII

Residual current monitoring with Doepke e.Guard

7. Residual current monitoring with Doepke e.Guard

7.1. ——— Intelligent residual current monitoring with e.Guard

Doepke e.Guard is a flexible, modular system consisting of hardware and software components for monitoring the condition of electrical installations. e.Guard continuously collects residual current data and provides information about the insulation resistance of the installation, thus eliminating the need for periodic insulation tests pursuant to DIN VDE 0105-100/A1. The e.Guard system also uses machine learning algorithms for predictive analysis of the installation condition. This allows for maintenance to be scheduled more effectively, for multiple activities to be performed at the same time and for expensive installation failures or serious damage, for example due to fires, to be avoided. This means interruptions can be effectively minimised and downtime costs reduced.

1.1.1. ——— The five levels within the e.Guard system

There are five levels within e.Guard to choose from depending on the desired scope of performance. This can involve using either tried-and-tested standard components or customised solutions. The spectrum ranges from proven hardware combined with streamlined software, to continuous monitoring, to intelligent, self-learning complete solutions based on machine learning algorithms.

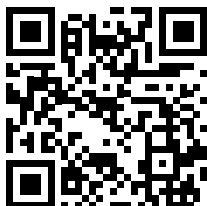
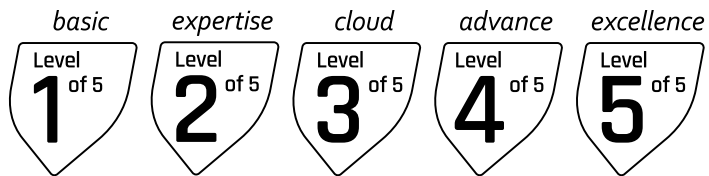

To the e.Guard landing page



e.Guard

basic – Level ONE of 5

SAVE TIME WHILE MAKING THE BEST POSSIBLE USE OF IT: RESIDUAL CURRENT VISUALISATION WITH LOCAL SOFTWARE (WINDOWS) AND DATA RECORDING

e.Guard basic combines smart RCMs with local monitoring software. With level ONE, residual currents are signalled and visualised, and the data is saved on a locally available hard drive, thereby implementing constant residual current monitoring as a substitute for periodic insulation tests.

e.Guard basic offers the following key functions:

- › Integration of up to 20 RCMs
- › Configuration of the RCMs
- › Adjustable threshold values for triggering an alarm and/or switch-off
- › Pre-warnings and alarms sent via email
- › Reports and logbook
- › Data stored and history kept for one year
- › Automatic backups and easy data export

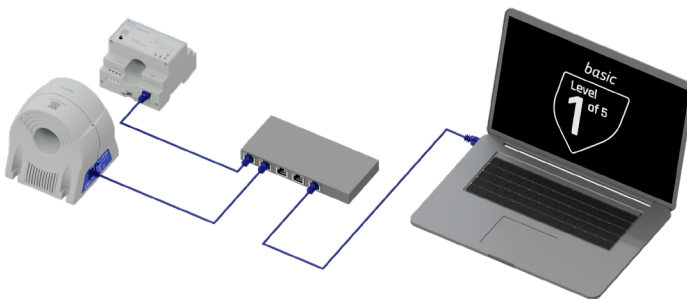

Fig. 20: e.Guard basic setup

e.Guard

expertise – Level TWO of 5

REPORTING BEFORE SWITCHING: CONTINUOUS MONITORING, ALERTING AND LOCAL DATA RECORDING ON THE e.Guard GATEWAY

e.Guard expertise combines smart RCMs with the e.Guard gateway for data management and software use. With level TWO, you therefore no longer need a PC to store data.

e.Guard expertise offers the following key functions:

- › Integration of up to 20 RCMs per e.Guard gateway
- › Configuration of the RCMs
- › Dashboard can be accessed via any standard internet browser
- › Custom thresholds for triggering an alarm and/or switch-off
- › Pre-warnings and alarms sent via email
- › Configurable reports and logbook
- › Data stored and history kept for one year
- › Backups and easy data export

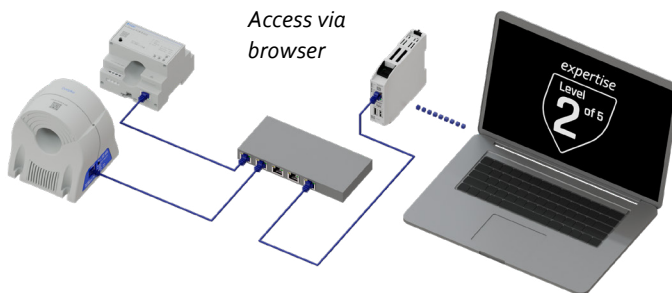

Fig. 21: e.Guard expertise setup



Doepke
e.Guard









Dashboard Online 3 / 3

- Übersicht
- Gateway
- Log
- Einstellungen
- Info

expertise
Level 2
of 5

Administrator

Logout

	Unterverteilung 1 <small>Abgang Beleuchtung</small>	DC 0 mA	AC 37 mA	50Hz <100Hz 150Hz	10 mA 0 mA 15 mA	100-1kHz 1kHz 10kHz	10 mA 15 mA 5 mA	 	Online
	Unterverteilung 1 <small>Abgang Produktion</small>	DC 0 mA	AC 260 mA	50Hz <100Hz 150Hz	10 mA 10 mA 100 mA	100-1kHz 1kHz 10kHz	100 mA 60 mA 20 mA	 	Online
	Unterverteilung 2 <small>Abgang Maschine 3</small>	DC 0 mA	AC 261 mA	50Hz <100Hz 150Hz	0 mA 0 mA 100 mA	100-1kHz 1kHz 10kHz	10 mA 15 mA 100 mA	 	Online

Neues Gerät hinzufügen
Neu laden

e.Guard Interface for Level TWO: Status display of the connected RCMs.

e.Guard

cloud – Level THREE of 5

ALWAYS AVAILABLE: USE SOFTWARE AND DOCUMENTATION ANY TIME, ANYWHERE – WITH THE AUDIT-COMPLIANT e.Guard CLOUD

e.Guard cloud combines smart RCMs with the e.Guard gateway. You can store data and use the software regardless of your location via the cloud.

e.Guard cloud offers the following key functions:

- › Integration of up to 40 RCMs per e.Guard gateway
- › Configuration of the RCMs
- › Custom alarm thresholds for triggering switch-off and/or an alarm
- › Audit-compliant, uneditable, date-stamped data storage in the e.Guard cloud
- › Data can be accessed at any time and from anywhere using any standard internet browser
- › Pre-warnings and alarms sent via email
- › Status map: Visualisation of alarm history
- › Data is stored in the maximum possible resolution (one value per second) for a year and the history is kept for seven years in a lower resolution
- › Configurable reports

*Identification of anomalies in residual current patterns from Level FOUR.
Power Quality Monitoring (PQM) incorporated from Level FIVE.*

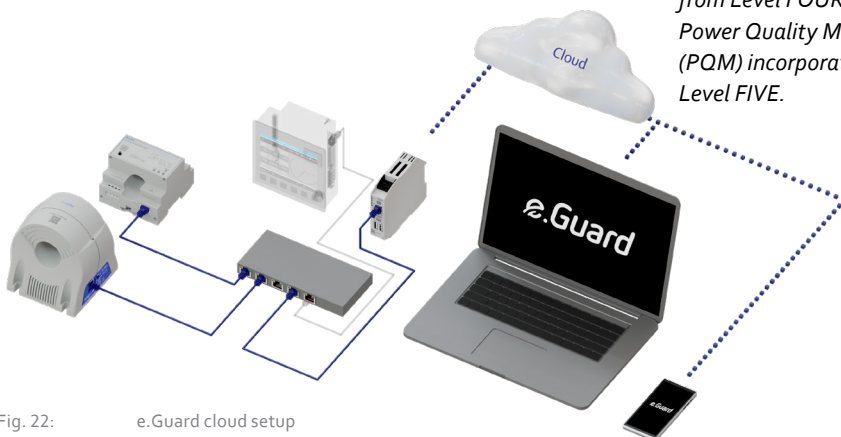

Fig. 22: e.Guard cloud setup



e.Guard

advance – Level FOUR of 5

LEARNING AND ADVANCE WARNINGS: CLOUD-BASED, MACHINE LEARNING ASSISTED ANALYSIS OF RESIDUAL CURRENTS WITH A WARNING SYSTEM FOR ANOMALIES

e.Guard advance uses the recorded residual current data together with machine learning methods to predict the future condition/status of the installation.

In addition to the functions of level THREE, e.Guard advance also offers the following key features:

- › Machine learning of individual residual current patterns during operation
- › Detection and notification of anomalies across all frequency components up to 100 kHz
- › Triggers an alarm if the threshold value is exceeded and if anomalies are detected in the residual current, e.g. creeping insulation faults, deterioration of EMC filters

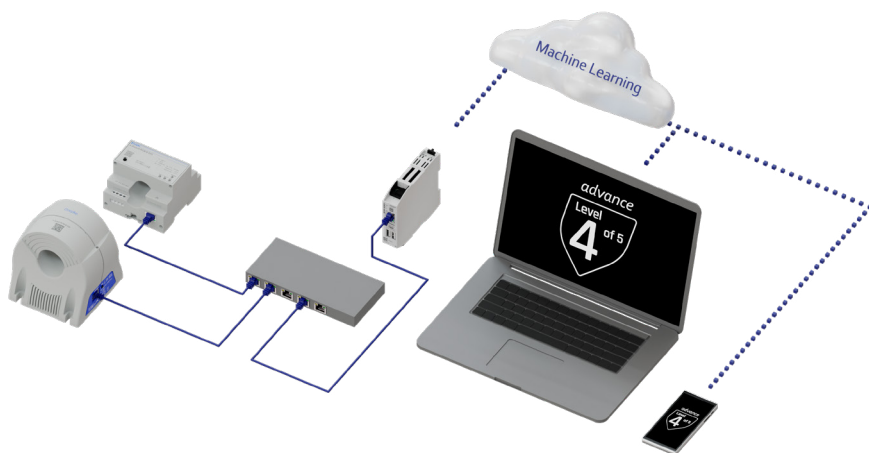

Fig. 23: e.Guard advance setup

THE RESPONSE TO DYNAMIC RISKS: A TAILORED SOLUTION FOR EVERY INSTALLATION WITH ADDITIONAL MEASURED PARAMETERS

e.Guard excellence is the individually tailored solution for predictive maintenance in relation to complex industrial installations.

In addition to the functions of levels THREE and FOUR, e.Guard excellence also offers the following key features:

- › A solution geared specifically towards the customer's requirements
- › Tailored machine learning meta data matched precisely to your needs
- › Customisation of the hyperparameters (which are required to control the machine learning training algorithm)
- › Customised interfaces with insurance providers and ERP systems, cloud-to-cloud interfaces

Normal operation

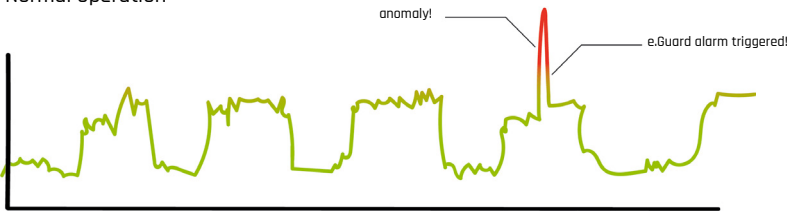

Fig. 24: Example of anomaly detection



Fig. 25: Screenshot from the e.Guard interface for Level FIVE.



OUR TOP PRIORITY IS TO KEEP APACE WITH
TECHNOLOGICAL CHANGE - BECAUSE WITHOUT
SAFETY, ELECTRICITY CANNOT BE USED WITH
COMPLETE PEACE OF MIND.

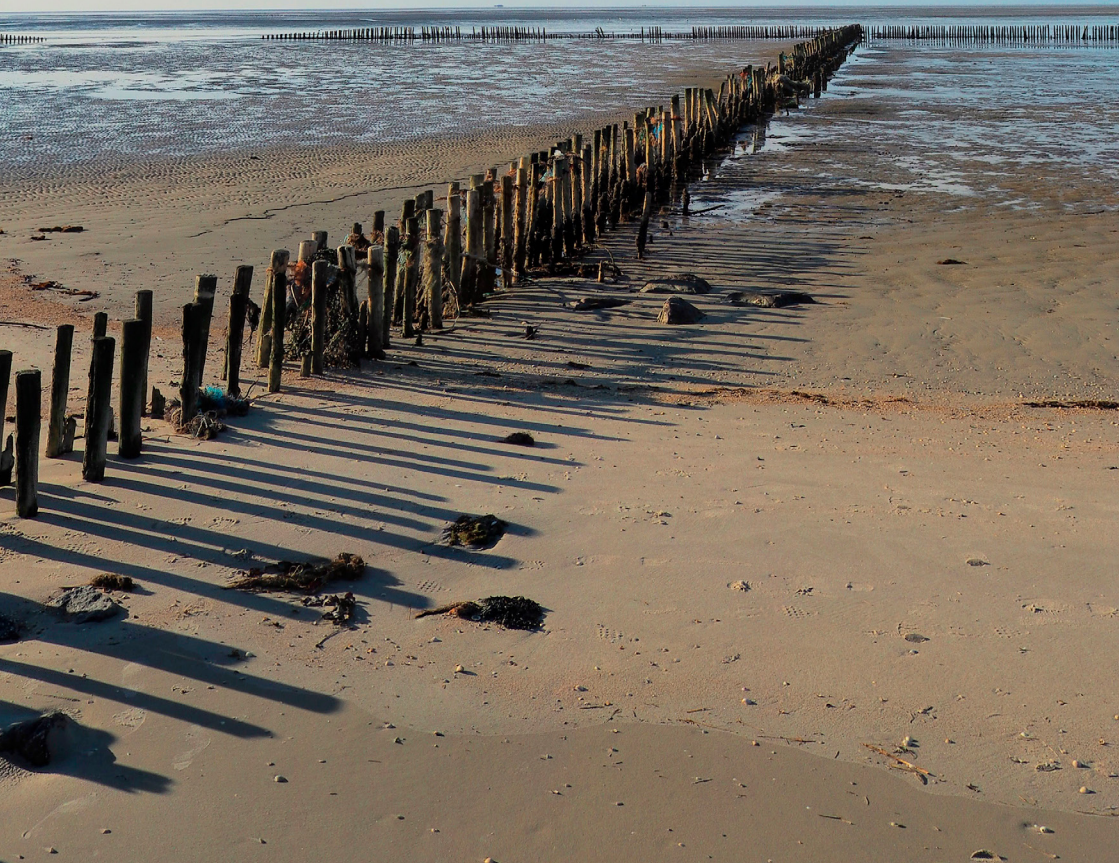

Part VIII

How to select residual current monitors (RCMs)



Through our training, we share our knowledge with our customers and are always on hand to offer support and advice.

Stefan Davids, Deputy Head of Technical Sales



8. How to select residual current monitors (RCMs)

8.1. Basic circuits for electronic equipment

Table 5 below shows the time curve for the load and fault currents for electronic equipment with various basic circuits, and also specifies which RCD/RCM types are suitable.

No.	Basic circuit with fault point	Load current profile	Residual current profile	Tripping characteristic				
				AC	A	F	B	B+
1	<p>Single-phase without rectification</p>			■	■	■	■	■
2	<p>Leading edge control</p>			■	■	■	■	■
3	<p>Burst control</p>			■	■	■	■	■
4	<p>Single-phase</p>			■	■	■	■	■
5	<p>Two-pulse bridge connection</p>			■	■	■	■	■
6	<p>Half-controlled two-pulse bridge connection</p>			■	■	■	■	■
7	<p>Frequency converter with two-pulse bridge connection</p>				■	■	■	■

No.	Basic circuit with fault point	Load current profile	Residual current profile	Tripping characteristic					
				AC	A	F	B	B+	
8	<p>Single-phase with smoothing</p>							■	■
9	<p>Frequency converter with two-pulse bridge connection and PFC stage</p>							■	■
10	<p>Two-pulse bridge connection between line conductors</p>							■	■
11	<p>Frequency converter with two-pulse bridge connection between line conductors</p>							■	■
12	<p>AC star circuit</p>							■	■
13	<p>Six-pulse bridge connection</p>							■	■
14	<p>Frequency converter with six-pulse bridge connection</p>							■	■

Table 5: Basic circuits for electronic equipment and suitable RCD/RCM type.



8.2. How to select RCM systems

Start

Is additional protection (personal protection) or protection via automatic switch-off as per DIN VDE 0100-410 required?

NO

NO

Are the connected loads:

- Frequency converters
- Pumping, air conditioning and ventilation systems
- Single-phase frequency converters with PFC
- Escalators, elevator systems
- Photovoltaic systems, welding systems
- UPS units?

YES

YES



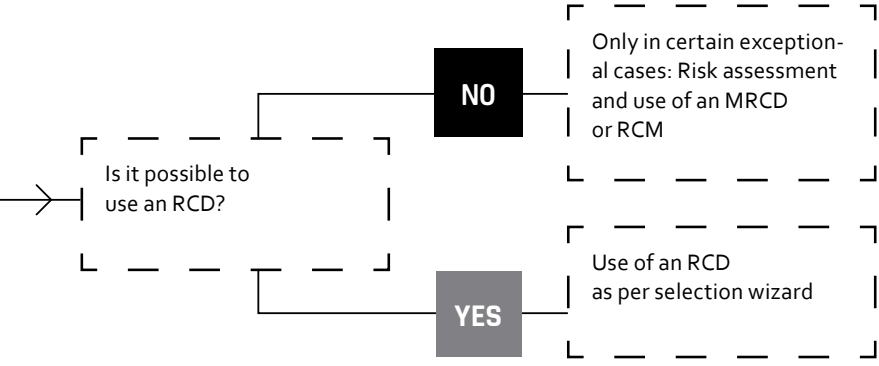
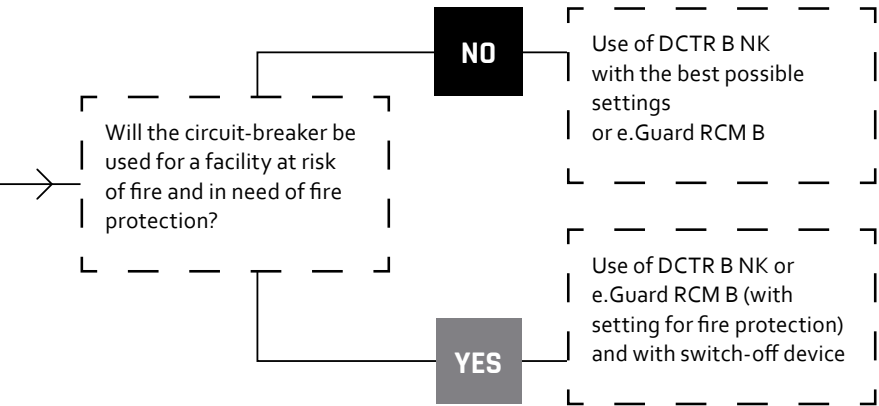
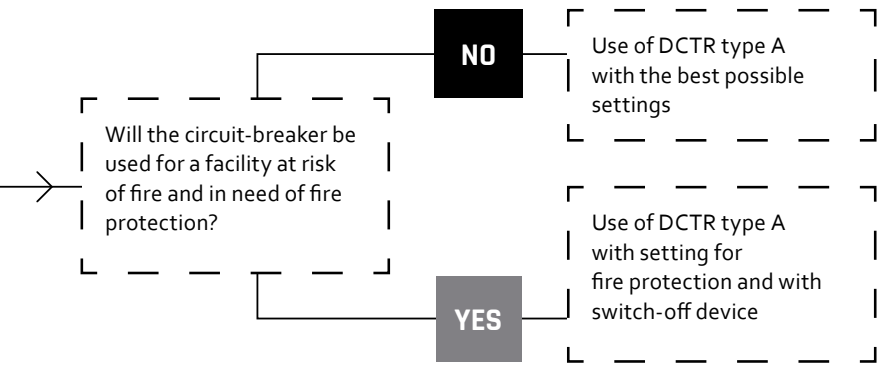

Part IX

Appendix

9. Appendix

9.1. List of abbreviations

Abbrevia- tion	Meaning
RCD	Residual current operated protective device: Residual current device
RCCB	Residual current operated circuit-breaker without integral overcurrent protection: Residual current circuit-breaker
RCBO	Residual current operated circuit breaker with integral overcurrent protection
MRCD	Modular residual current device
RCM	Residual current monitor
EMC	Electromagnetic compatibility
FC	Frequency converter
PE	Protective earth
RF	Fault resistance
IF	Residual current
INV	Inverter

Table 6: Overview of abbreviations

9.2. Item numbers

Designation	Item numbers
DRCM 1 A	09340250
DMRCD 1 A	09340350
DCT A-020	09340320
DCT A-035	09340321
DCT A-070	09340322
DCT A-105	09340323
DCTR A 020/0.30-I	09342621
DCTR A 035/0.30-I	09342631
DCTR A 070/0.30-I	09342641
DCTR A 105/0.30-I	09342651
DCTR B NK 020/0.30-I	09344622
DCTR B NK 035/0.30-I	09344632
DCTR B NK 070/0.30-I	09344642
e.Guard RCM B 025	09344367
e.Guard RCM F 025	09346367
e.Guard RCM B 035	09344937
e.Guard RCM B 070	09344947
e.Guard gateway	09344989



